

Viabizzuno facts and figures

our manifesto

at Viabizzuno we believe in the timeless art of craftsmanship made in Italy as an essential expression of human civilisation to create, produce, care and regenerate refined and unique lighting products. study, control and reliability guide our actions, leading to industrialisation based on the highest quality of materials and use of the most sophisticated technologies.

we take care of light. for us, this means taking care of people - colleagues, designers, customers - also by generating and disseminating lighting culture to create well-being, in a harmonious synthesis of natural and artificial light, acknowledging their power to define the relationship between human beings and built space.

curiosity leads us to listen to both the customer and the architecture. training and educating in searching for the right light has been one of Viabizzuno's aims since day one. we dialogue with the masters of architecture and with brilliant young design studios all over the world with the same passion and dedication. this ongoing exchange of ideas has taught us to place ourselves at the service of unique architectures, exercising delicacy and respect in drawing integrated, customised, exclusive lighting designs, capable of enhancing the architectural lines. challenges give rise to extraordinary products and customised realisations endowed with a soul.

our orientation towards sustainability guides us in engineering systems that reduce energy consumption, installation and maintenance costs; in assembling appliances that can be repaired and regenerated to last forever.

our V

we introduce the V, a sign that originates from our own logo to give shape to our distinguishing traits: craftsmanship and industrialisation, materials research, design precision and creativity.

it is not a decorative element. it is a discreet signature, designed to accompany our objects and communication tools with coherence and care: a recognisable, essential detail, capable of narrating the Viabizzuno identity.

the V thus becomes a point of continuity between design and material, between idea and realisation: a linear graphic sign charged with meaning.

our numbers

founded in 1994

*11 light laboratories in the design capitals
16 Viabizzuno partners worldwide*

*3 made in Italy production factories: bentivoglio
desio
argenta*



Viabizzuno experience



bentivoglio



Viabizzuno racconta



design thinking



Viabizzuno hospitality



Viabizzuno atelier



certified in-house laboratories



human skills



technical



furnishing systems



linear systems



decorative

engineering beauty

efficiency, quality, reliability.



emergency lighting systems



atelier



architecturally integrated systems



connectivity

application segments



Bologna Business School Campus bologna, italy

work ■

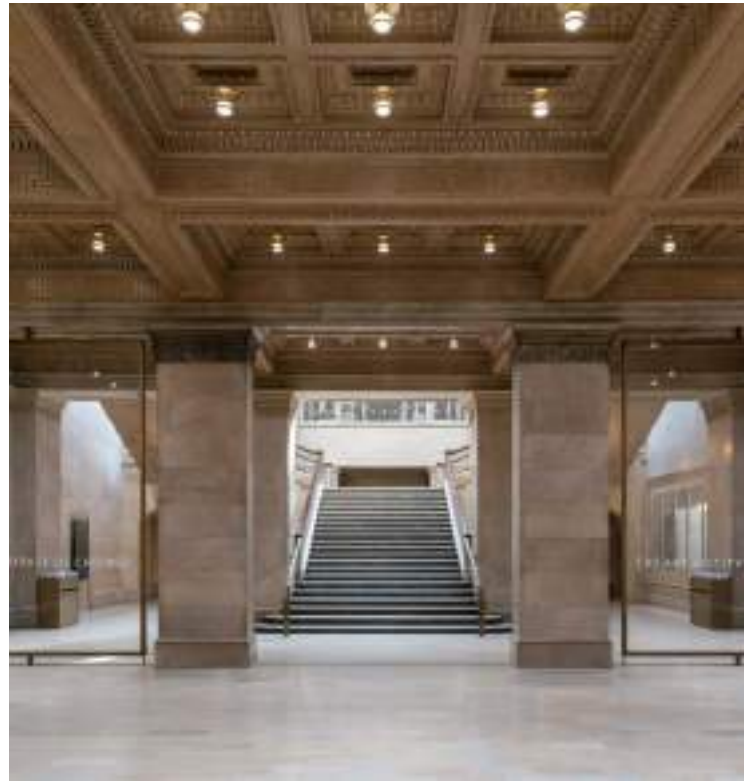

The Art Institute of Chicago chicago, usa

culture ■



SKS showroom chicago, usa

retail ■



Villa Vanke Dajia suzhou, china

residential ■



Telegraph Hotel tbilisi, georgia

hospitality ■

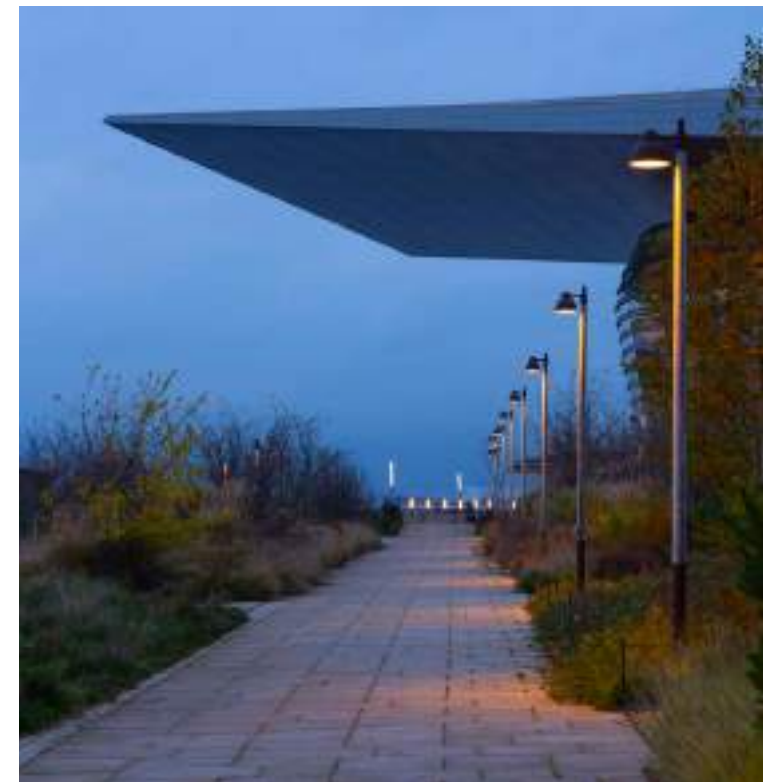

Operaparken copenhagen, denmark

outdoor ■

global references



EssilorLuxottica Corporate Office new york, usa



Apl new york, usa



The Royal Academy of Arts london, united kingdom



Galeries Lafayette paris, france



Secular Retreat devon, united kingdom



Piazza del Nettuno bologna, italy



Gabriele Basilico. Le mie città milan, italy



Amorepacific seoul, south korea

Viabizzuno laboratories



bentivoglio



amsterdam



barcelona



london



miami



milan



munich



new york



paris



beijing



shanghai



vienna

Viabizzuno partner



hamburg



bilbao



civitanovamarca



dubai



lisbon



lugano



manila



melbourne



padua



riccione



riga



rome



seoul



sydney



tel aviv



tokyo

Viabizzuno atelier

Viabizzuno atelier is the place where **lighting design** becomes **care**. care for the project, for relationships, for details and for time. a dialogue with customers to build the experience and project value with them, accompanying them with competence, vision and responsibility. Viabizzuno interprets needs, context and ambition, transforming them into a conscious creative path in which light is not just a technical solution, but a thought-out, guided and shared experience. a holistic approach is adopted towards all project phases, from the **initial consultation** to **design, overview** at the **worksite**, and **supervision of the installation**. the service continues with **focusing, after sales** and **relamping** or **regeneration** activities, guaranteeing timeless quality. Viabizzuno atelier works on unique, custom-designed projects, supporting retail and executive clients with design, planning and operational assistance, accompanying the project through all phases of its life cycle. this is complemented by the ability to develop customised lamps and products born out of partnerships with architects and designers for solutions that perfectly interweave light and architecture. Viabizzuno atelier is also **innovation**. the use of **artificial intelligence** supports workflows and encourages the development of tools to support customer care. Viabizzuno atelier is, in short, a place of design and service, where vision, expertise and care are transformed into coherent, personalised and lasting lighting experiences.



moodboard

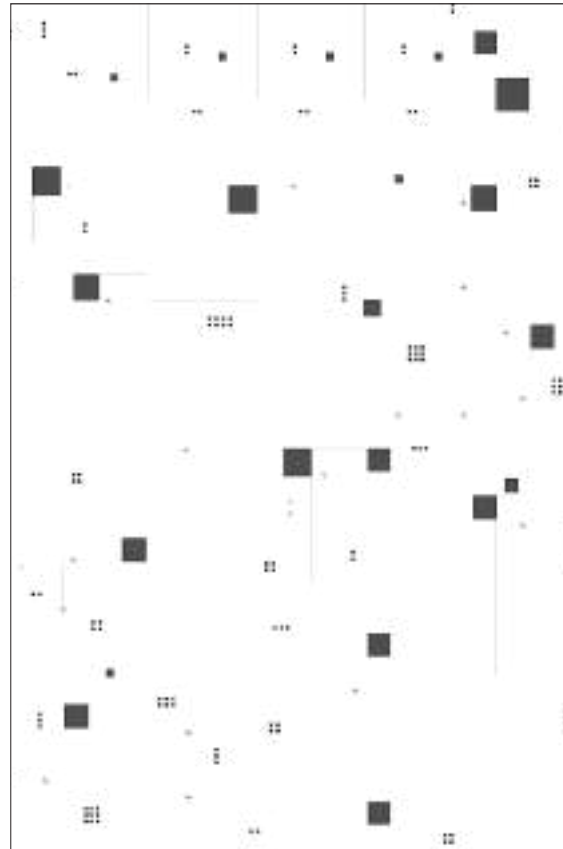

concept



preliminary project

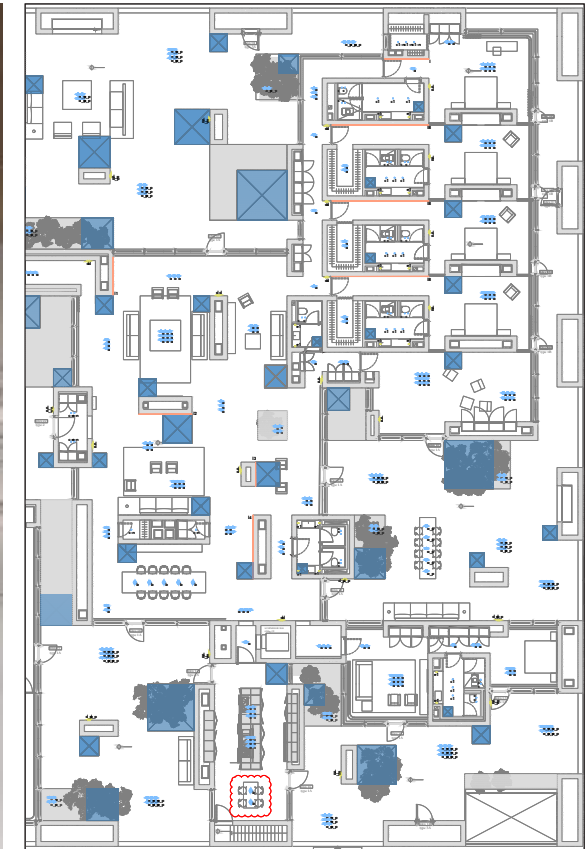

executive project

Viabizzuno services

1. technical training

training on Viabizzuno lighting systems, emergency lighting and lighting control systems.

2. technical inspections

inspection by specialised Viabizzuno technicians for measurement, surveying and verification activities.

3. control systems

design and supply of specific control systems for lighting. the service includes commissioning, programming, training and also maintenance of the systems, either on-site or remotely. dynamic, effect and multimedia interaction control systems are included.

4. project management

time control through the creation of dedicated gantt charts, retro-planning, site criticality management, strategic delivery management, cost control of the entire order, promotion and activation of dedicated services.

5. site support

support activities for installers and the general contractor during site activities to guarantee state-of-the-art installation. this includes dedicated logistical support, interventions by specialised technicians, supervisory inspections and checks by Viabizzuno technicians.

6. aiming and system finalisation

dedicated verification, aiming and programming activities in the final phase of the site, and after system completion.

7. event assistance

on-site assistance by specialised Viabizzuno personnel in support of major events, inaugurations, and visits.

8. warranty extension

warranty period extension service.

9. regular maintenance

planned maintenance activities to regularly check the system and update both configuration and aiming. extraordinary maintenance and verification activities can also be enabled.

10. rental for events

rental of fixtures for temporary events, such as art exhibitions, trade fairs, touring events. includes installation, calibration and aiming by specialised Viabizzuno technicians

11. solutionVia lighting system regeneration

regeneration of existing lighting systems by replacing old sources with new professional led technology, using appropriately dissipated high quality sources, instead of commercial bulbs.

12. financing solutions

tailored financing solutions arranged through leading banking institutions, structured around each project's timeline and specific requirements. also includes operating lease options.

Viabizzuno uniqueness



innovation



craftsmanship



industrialisation



recognisability



services



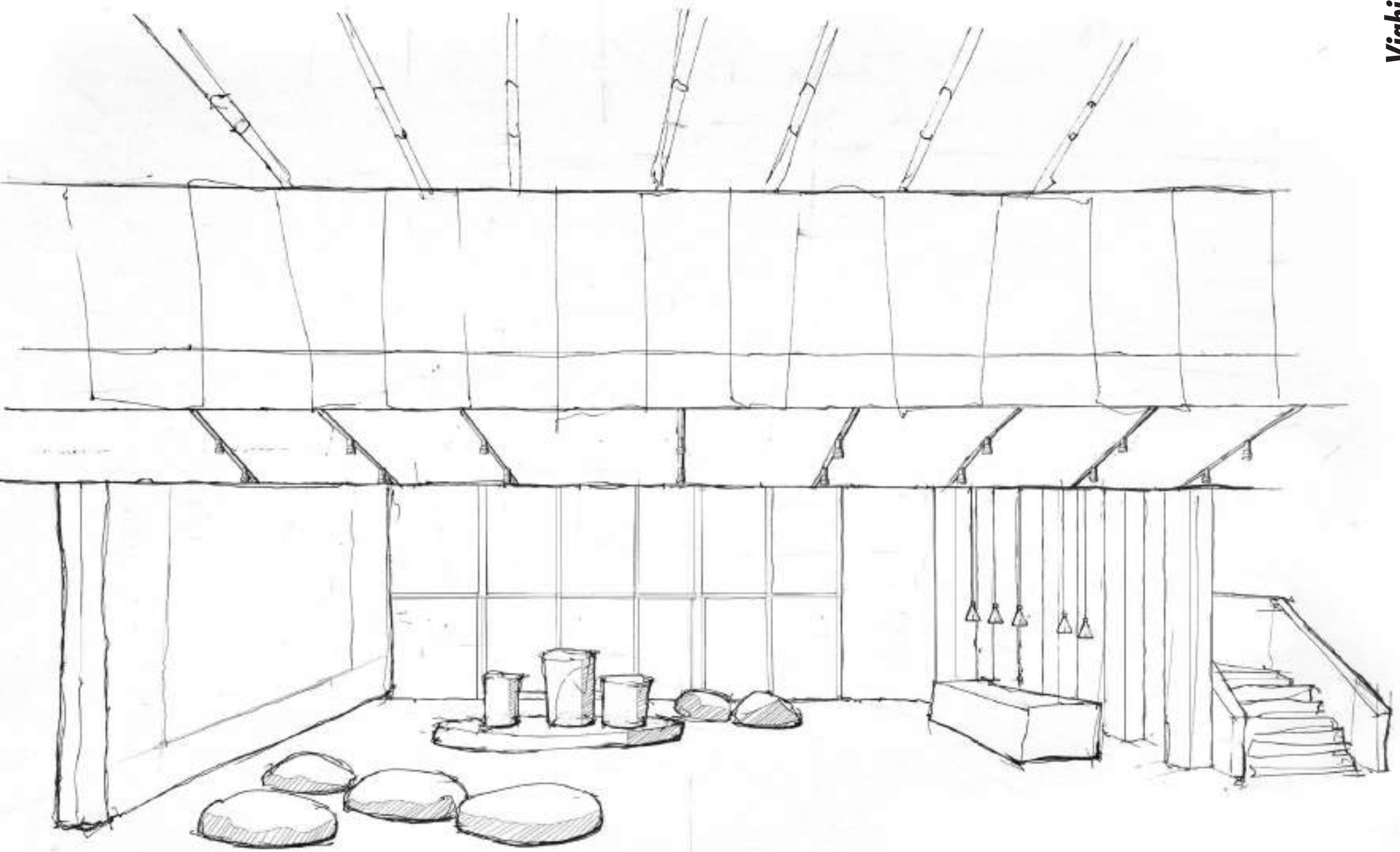

lighting for work

successful offices create a narrative connection and an emotional transformation to capture people's attention. the workplace is considered an 'ecosystem of experiences' designed for presence, not just frequency. modern workspaces must attract top talent and make them feel comfortable to express their full creative potential. light is an essential element at the service of the individual to guide, stimulate, make people feel safe, and ensure a sense of orientation at all hours of the day by setting the stage for key elements of the corporate journey, enhancing the beauty of architecture, and efficiently maximising savings by making the most of natural light. flexibility plays a central role, moving from a rich ecosystem of quiet corners to focus on dynamic hubs for collaboration and gathering areas. biophilic design (connecting with natural elements), natural light and advanced air quality systems are integrated to enhance the human experience and increase productivity and well-being. offices use data-driven information to guide design decisions and optimise environmental conditions such as temperature and co² levels in real time, making spaces smarter and more agile.

the intentionally chosen colour for work lighting is forest green, which reminds us of sustainability, waste reduction and energy efficiency. the sense of balance between human beings, work and nature is also sought by rational and scrupulous measurement of lighting parameters.

discover more



www.Viabizzuno.com

high efficiency

visual comfort

connectivity

contemporary design

value propositions

frequent errors



is this a place that can attract top talent?

- constant horizontal light
- 500 lux everywhere
- an environment lacking personality
- high energy costs
- no support for creative activities
- no well-being or comfort



flexibility able to support any layout variation



acoustic comfort acoustic environment ideal for concentration



architectural enhancement capable of highlighting beauty

Viabizzuno quality configuration



- flexible spaces capable of attracting the best talent
- light that inspires creativity and boosts productivity
- high visual and acoustic comfort
- low environmental impact and costs
- maximum energy saving (3 W/m² depending on lighting configuration)
- additional energy savings related to light and presence sensors
- infinite customisation possibilities
- connectivity via Viascenario



versatile adaptable to any design requirement



connectivity remote lighting control for sustainable and intuitive management of installations

mn sistema



comprehensive and innovative product family with over 2200 serial items for modern and flexible workspaces

- best use of **natural light** for well-being and **energy saving**
- average led life **80,000** hours (27 years, 8 hours per day)
- **secondary aluminium**
- **low number of components**
- **durable and recyclable materials** obtained through manufacturing processes (extrusion, die-casting, injection moulding) that guarantee very high quality standards, precision and optimisation of raw materials
- **easy disassembly and replacement** of components, assembled without welding or glue.
- efficient use of light through **control systems and sensors**
- **100% recyclable packaging** composed of **FSC certified paper** and shrink plastic film to reduce the use of plastic without impairing product integrity.
- part of the **ESG programme** (see our report on Viabizzuno.com)



ugr<19
UNI EN
12464-1:2021



ugr<16
leed certification



ugr<16
well certification

IP20 direct-light indoor lighting system with painted aluminium body and 359° rotatable matt black anti-glare screen on the adapter.

finishes

argento hacca, nero55, biancoV

versions

on-off, dali, casambi
2700K, 3000K, 3500K

maximum visual comfort

44° beam
ugr<10
Lm $\gamma > 65^\circ < 1000\text{cd/m}^2$
Lm $\gamma > 45^\circ < 6000\text{cd/m}^2$

70° beam
ugr<19

latest generation LEDs

Ra97: 135 lm/W

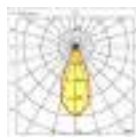

ugr<10
44° beam

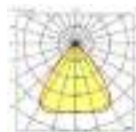

ugr<19
70° beam



models

130x130

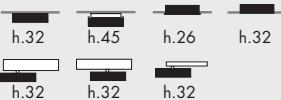

130x250

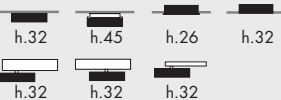

250x250

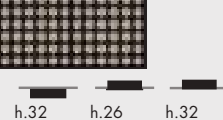

130x370

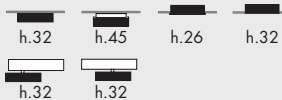

580x580

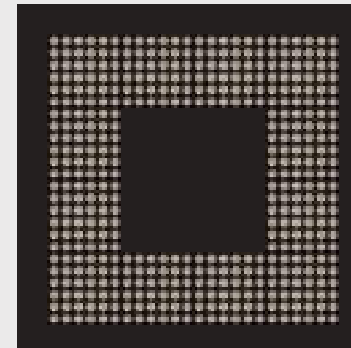

floor

30x370

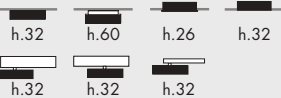

30x730

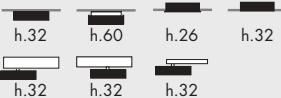

30x1450

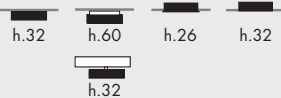

applications

- ceiling
- ceiling-mounted with integrated power supply
- recessed
- fully recessed
- traccia sistema 24Vdc
- A sistema 48Vdc
- binario VbB 230V



floor

iconic projects



EssilorLuxottica Digital Factory milan, italy

flexibility and sharing in a technologically innovative architectural space



Amorepacific seoul, south korea

a volume of over 200,000 square metres in which light combines quality, atmosphere and sustainability



Dior headquarters paris, france

two historic buildings in the centre of paris, covering a total area of 15,000 square metres



Casa Ria santiago de compostela, spain

a historic building transformed into a venue for exchanging ideas, and for conducting research and training

lighting for work

global references



UniFor milan, italy



Palazzo Ancilotto treviso, italy



El Trull albagés, spain

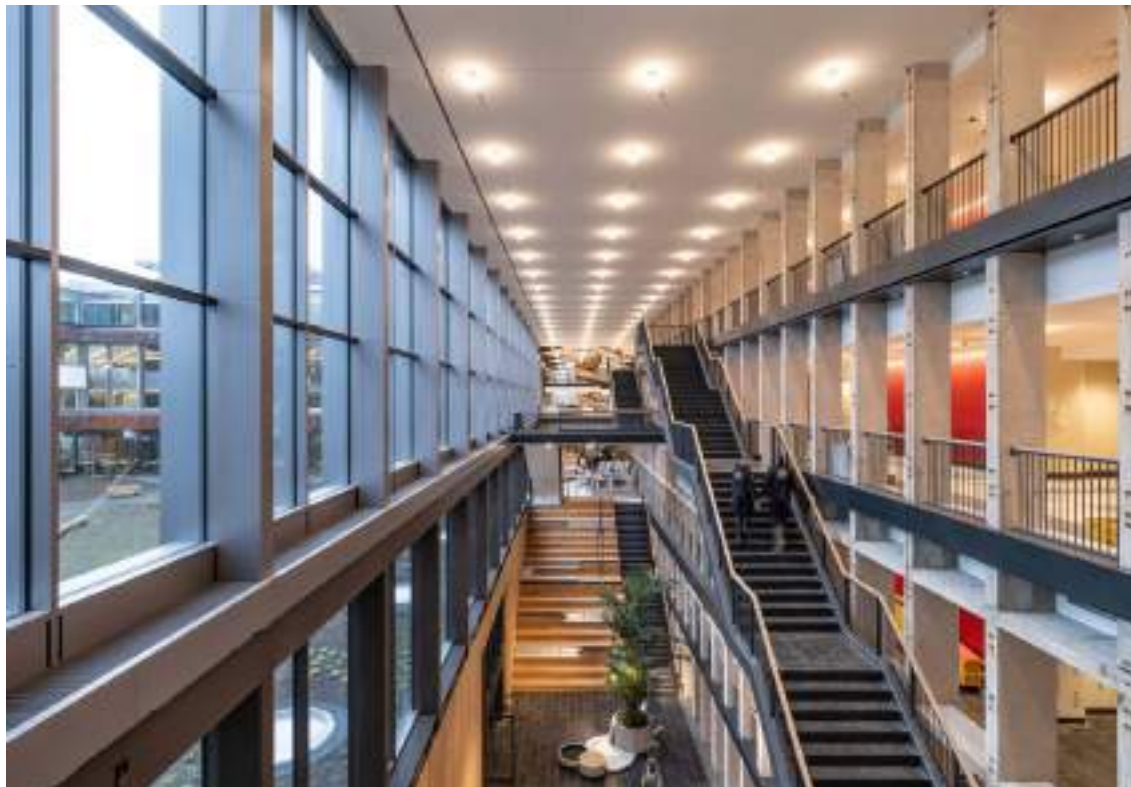

De Nederlandsche Bank amsterdam, the netherlands



Haus Balma vals, switzerland



Beike library jiangsu, china



Galenicum barcelona, spain



EssilorLuxottica corporate office new york, usa



Alinso offices polytoren te zwijnaarde, belgium



Regus geneva, switzerland



David Chipperfield Architects offices milan, italy

products

ceiling



n55 soffitto



mn sistema



light box



amP



c sistema

technical suspension



mn sistema



alba



n55 sospensione



officina zumthor



sistema il silenzio

decorative suspension



coppibartali



da ma



tisoffio



c2 anelli



bacchetta magica

recessed

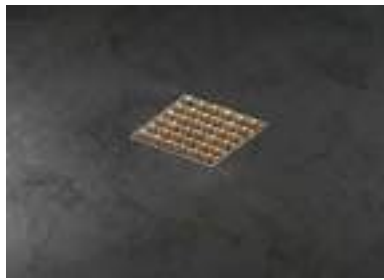

mn sistema



mn sistema



m1 micro incasso



094 sistema



foro

wall



coppibartali



quasi



n55 h20



n55 parete con braccio



royal parete

**table
floor**



mn sistema



traccia terra



roy lettura



roy tavolo



microsolo

**230V
track**

binario trifase VbB



mn sistema



mn sistema



mn sistema



n55 binario



econo binario

**24Vdc
track**

traccia sistema



micromen



mn sistema



mn sistema



ecomini



n55 orientabile

**48Vdc
track**

A sistema



n55 lensoptica



n55 spot 82x79



n55 spot 82x35



n55 spot 55x61



n55 sagomatore

**connectivity
emergency
wired systems**



Viascenario



trasparenze



n55 emergenza



ticablo



ariacablata

offering



officina zumthor

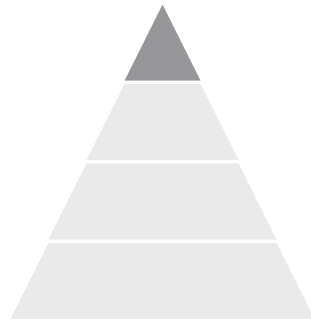

mn sistema

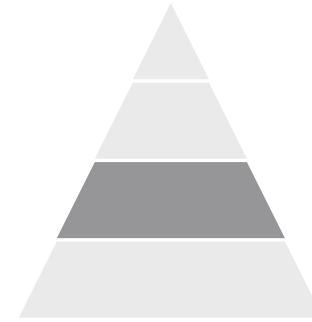

n55 lensoptica

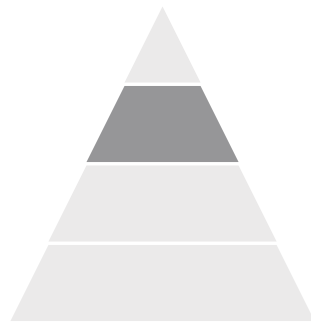

alba

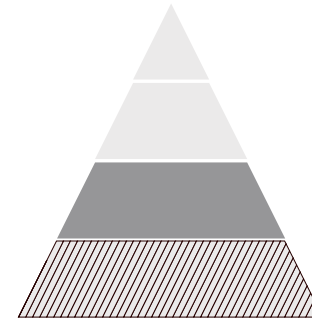

we take care

care is an extraordinary word. short and apparently simple, it encompasses many meanings, which are inextricably linked. *care* from the latin *cūra, curae*. the meaning changes according to the scope. its fields of application are numberless, spanning society and government, religion and architecture. *cūra* is *concern, care, attention* and – by abstraction – *love*. it is also *administration, custodianship, ornamentation, study* and *curiosity*. in medicine, *cūra* means both *giving care* and *taking care*. by no mere coincidence this important word is linked to another latin term: *cor, cordis*, i.e. *heart*. their fusion gives rise to the archaic term *coira*, meaning *care, solicitude* and *medical treatment*, suggesting an origin associated with deep interest and feeling.

Viabizzuno's design approach is based on craftsmanship combined with the highest technology standards to create products that are proudly made in italy. timeless, eternal and outside the trends of fashion products. creativity, tailoring approach and service excellence are our guiding principles, enabling us to take the customers by the hand, accompany them through our experience and take care of every aspect. our industrialisation capacity makes us solid and reliable.

we are curious, we care, we are concerned. at Viabizzuno, the word *care* in all its forms – from the most concrete to the most abstract – characterises every activity. curiosity drives our search for new solutions, new materials, and new opportunities. challenges thus generate amazing products and customised creations endowed with a soul. we take care of every step of a project, from the embryonic light fitting design stages to the final delivery, from the still untouched blank canvas to the installation of products, and beyond. we strive to be present, always and everywhere, with a sense of responsibility, attention and readiness, to ensure a service that always matches the quality we strive for. we treat our products as artistic creations.

the world is moving fast. technology is progressing at a rapid pace, influencing our lives. artificial intelligence impacts our perception of things and of the world. languages and words evolve, throwing open portals to new worlds and unprecedented interpretations. yet, the word *care* has remained unchanged for two thousand four hundred years, both in form and in substance. likewise, Viabizzuno transforms, matures and broadens its horizons, but its thought is based on certain pillars – craftsmanship, research, industrialisation in the service of quality – to which it has remained faithful since its foundation.

our team's commitment, dedication and passion allow us to create unique products and extraordinary designs studied to enhance any architectural space, making it recognisable. the human factor remains a central distinguishing trait. the care our people seek and demonstrate is what sets us apart.

Viabizzuno uniqueness



innovation



craftsmanship



industrialisation



recognisability



services



EssilorLuxottica Digital Factory milan, italy

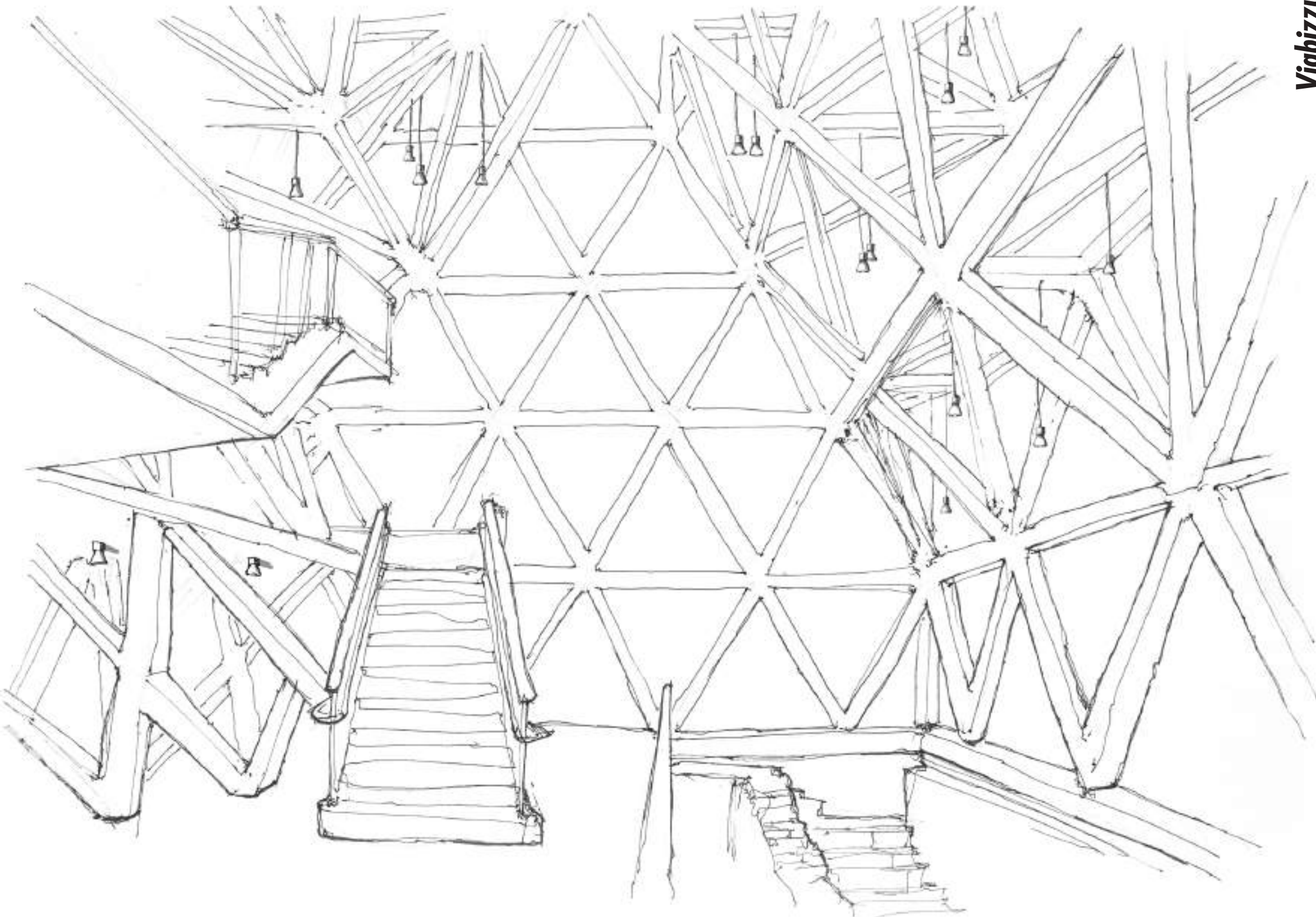

lighting for culture

collecting, preserving, exhibiting: culture thrives on a delicate balance. light can either enhance a work or debase it. hence, in an exhibition space, light is not merely a system, but a curatorial choice, an act of respect. Viabizzuno designs lighting capable of protecting and narrating. it guarantees controlled quality to comply with conservation constraints; faithful colour rendering to reproduce materials and unaltered colours; high-precision shaping for a light beam with sharp contours. light only focuses on the object, without dispersion on walls or reflections on display units and glass. we design lighting scenarios that guide the gaze: a discreet base for orientation, calibrated accents to create rhythm, and precise details to let the work speak. lighting direction does not stop at the rooms. it starts from the outside, enters the building, accompanies the visitor to the foyer, reaches the works on display, and continues through the spaces that complete the visit, namely the cafeteria, bookshop and rest areas.

when the set-up changes, there is no need to start from scratch: the system remains, reconfigures and realigns quickly, reducing time and interventions even in historic buildings and heritage-protected areas. thanks to connectivity and remote control, lighting scenarios become consistent and replicable over time: a simple, sustainable, and flexible management system, ready for temporary exhibitions, events and different usage needs. the result is a clear and inclusive experience: light accompanies the visitor, enhances art, and protects its precious features.

the intentionally chosen colour for culture is burgundy red. its depth calls to mind both the great theatrical curtains and artistic passion. the vital energy of red is a light capable of both enhancing and respecting works of art.

discover more



www.Viabizzuno.com

preservation of works

precision and shaping

colour fidelity

connectivity

value propositions

frequent errors



is this how we value art?

- risk of damaging art works
- inaccurate beams and dispersions
- glare and reflections on display units and glass
- slow and expensive set-up changes



flexibility the possibility to modify the layout and combine general lighting with accent lighting

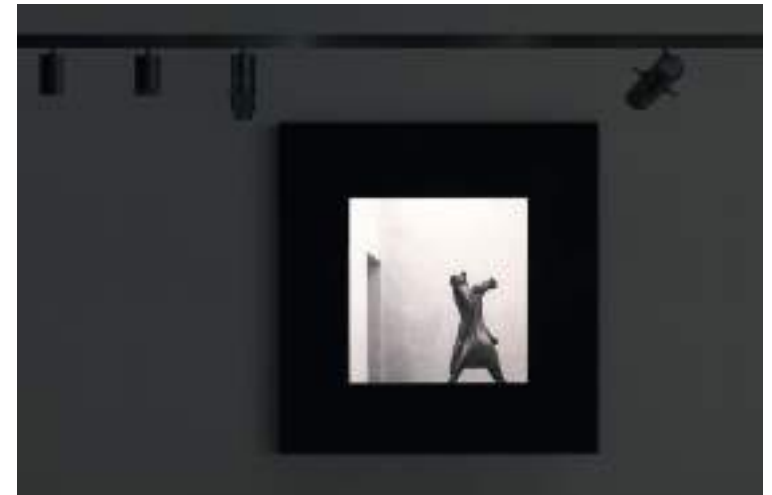

valorisation capable of enhancing beauty



conservation controlled lighting quality to protect works



safety design solutions to guide visitors through inclusive spaces

Viabizzuno quality configuration



- very low damage factor
- high-precision shaping: clean beam cut, light only on the artwork
- light hierarchies: general plus accent lighting to guide the gaze
- flexibility: quick reconfiguration when changing the set-up
- connectivity: recallable scenes and remote/centralised control
- versatile installation: solutions also suitable for historic buildings and plant engineering constraints
- safety and inclusion: lighting for visitor pathways, orientation and comfort



versatile easy installation for temporary exhibitions in historic buildings



connectivity remote lighting control for sustainable and intuitive management of installations

Viabizzuno profile spotlights



trentotto sagomatore



n55 sagomatore

Viabizzuno optics that illuminate art.

the ultimate lighting solutions for museum spaces and art galleries.

frames the artwork and enhances its characteristics with very high precision, maximum light quality, and a very low damage factor.

best use of **natural light** for well-being and **energy saving**

average led life **50,000** hours (17 years, 8 hours per day)

recyclable packaging, composed of paper and high-strength plastic film for wrapping products, protecting them from impact and vibrations

efficient use of light through **control systems and sensors**

part of the **ESG programme** (see our report on viabizzuno.com)

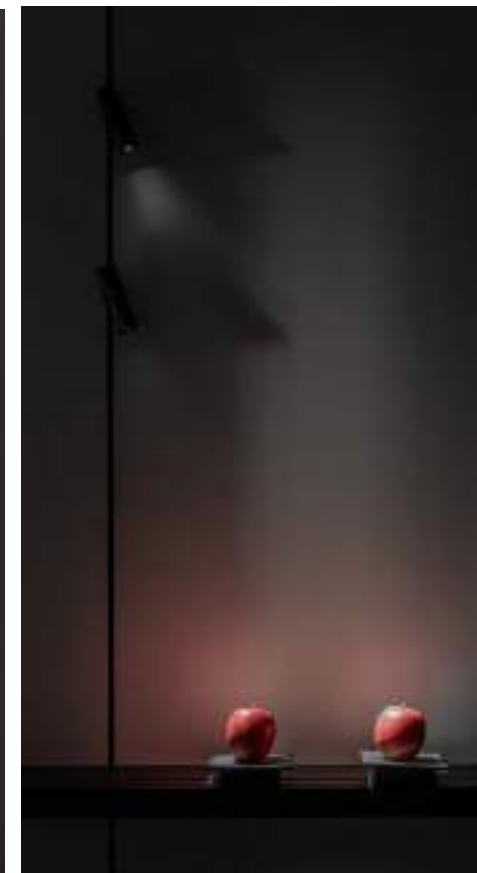

trentotto sagomatore zoom

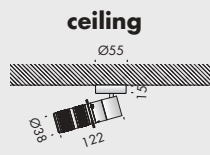

trentotto sagomatore fisso



fully recessed

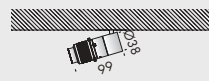
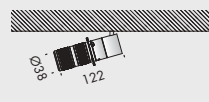

traccia sistema

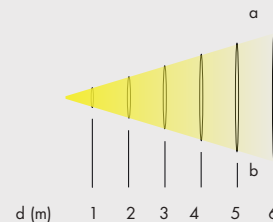
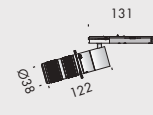

trentotto sagomatore zoom 21°

d (m)	ab (m)	E _{max} (lx)	E _{med} (lx)
1	0,37	2958	2137
2	0,74	740	534
3	1,12	329	237
4	1,48	185	134
5	1,86	118	85
6	2,24	82	59

trentotto sagomatore zoom 32°

d (m)	ab (m)	E _{max} (lx)	E _{med} (lx)
1	0,58	1252	856
2	1,16	313	214
3	1,74	139	95
4	3,30	78	53
5	2,88	50	34
6	3,46	35	24

trentotto sagomatore fisso

d (m)	ab (m)	E _{max} (lx)	E _{med} (lx)
1	0,98	512	314
2	1,96	128	79
3	2,94	57	35
4	3,94	32	20
5	4,92	20	13
6	5,90	14	9

n55 sagomatore zoom



n55 sagomatore fisso

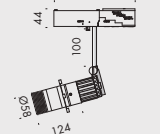

n55 binario

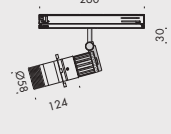
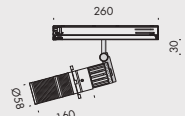

n55 parete soffitto orientabile

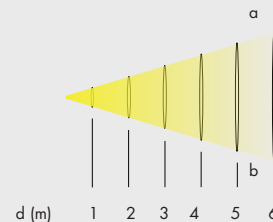
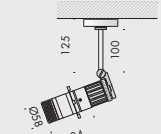
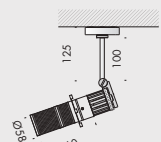

n55 sagomatore zoom 18°

d (m)	ab (m)	E _{max} (lx)	E _{med} (lx)
1	0,32	9980	6437
2	0,62	2495	1609
3	0,94	1109	715
4	1,26	624	402
5	1,58	399	257
6	1,88	277	179

n55 sagomatore zoom 32°

d (m)	ab (m)	E _{max} (lx)	E _{med} (lx)
1	0,58	4104	2950
2	1,16	1026	737
3	1,72	456	328
4	1,14	256	184
5	2,86	164	118
6	3,42	114	82

trentotto sagomatore fisso

d (m)	ab (m)	E _{max} (lx)	E _{med} (lx)
1	0,96	1713	1141
2	1,96	428	285
3	2,88	190	127
4	3,84	107	71
5	4,80	69	46
6	5,76	48	32

iconic projects



Gabriele Basilico. Le mie città milan, italy an unconventional lighting solution for an architectural space of great cultural value



Glenstone Museum potomac, usa art, architecture, nature and light come together in a contemplative environment



The Royal Academy of Arts london, uk one of the world's oldest cultural institutions open to the future



Medici Chapels florence, italy michelangelo's masterpiece emblem of italian art and history

global references



Cinema Modernissimo bologna, italy



The Art Institute of Chicago chicago, usa



Sala del Quirinale, sala dell'Annunziata rome, italy



David Hockney incontra Beato Angelico florence, italy



Maat Museum lisbon, portugal



Historical Oberamteistraße Museum reutlingen, germany



Siyadi Pearl Museum muharraq, bahrain



Basilica di Santo Stefano bologna, italy



Teatro della Cometa rome, italy



Labirinto by Arnaldo Pomodoro milan, italy



Casa Batlló barcelona, spain



Marina Abramovic, Between Breath and Fire bergamo, italy



Arte e natura. Pittura su pietra tra Cinque e Seicento bergamo, italy

products

ceiling



trentotto



light box



n22



n55 soffitto



cilindro 58

technical suspension



n55 sospensione



094 sistema



alba



catenaria di luce serpentine



traccia sistema sospensione

decorative suspension



coppibartali



candela di vals



n22 sospensione



royal chandelier



tisoffio

recessed



micromen



profili lineari



m1 micro incasso



094 sistema



foro

wall



coppibartali



light box



corrimano in luce



n22 parete con braccio



quasi

**table
floor**



traccia terra



da ma



n55 tavolo



roy



n55 lanterna

**230V track
binario trifase VbB**



n55 binario lensoptica



n55 binario spot100



ecomini binario



mn sistema



econo binario

**24Vdc track
traccia sistema**



micromen



trentotto



trentotto sagomatore



ecomini



n55 orientabile

**48Vdc track
A sistema**



n55 lensoptica 180



n55 spot 82x79



n55 spot 82x35



n55 spot 55x61



n55 sagomatore

**connectivity
emergency
wired systems**



Viascenario



trasparenze



n55 emergenza



ticablo



ariacablata

offering



A sistema with n55 lensoptica

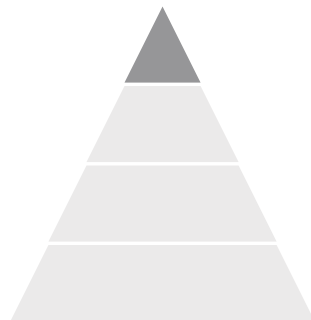

binario trifase VbB with econo

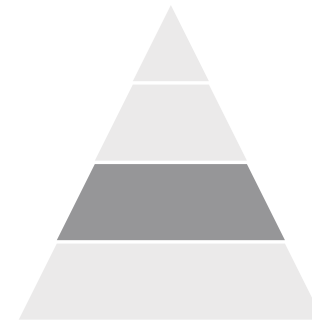

binario trifase VbB with n55

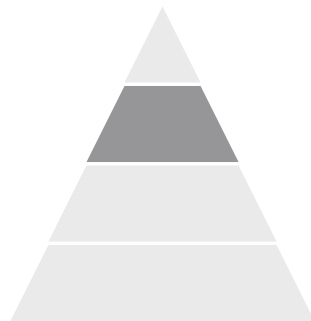

traccia sistema with trentotto

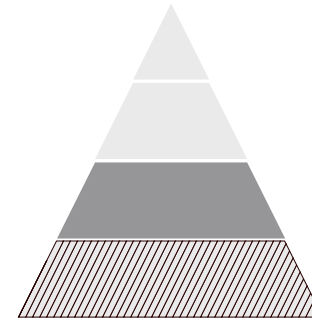

we take care

care is an extraordinary word. short and apparently simple, it encompasses many meanings, which are inextricably linked. *care* from the latin *cūra, curae*. the meaning changes according to the scope. its fields of application are numberless, spanning society and government, religion and architecture. *cūra* is *concern, care, attention* and – by abstraction – *love*. it is also *administration, custodianship, ornamentation, study* and *curiosity*. in medicine, *cūra* means both *giving care* and *taking care*. by no mere coincidence this important word is linked to another latin term: *cor, cordis*, i.e. *heart*. their fusion gives rise to the archaic term *coira*, meaning *care, solicitude* and *medical treatment*, suggesting an origin associated with deep interest and feeling.

Viabizzuno's design approach is based on craftsmanship combined with the highest technology standards to create products that are proudly made in italy. timeless, eternal and outside the trends of fashion products. creativity, tailoring approach and service excellence are our guiding principles, enabling us to take the customers by the hand, accompany them through our experience and take care of every aspect. our industrialisation capacity makes us solid and reliable.

we are curious, we care, we are concerned. at Viabizzuno, the word *care* in all its forms – from the most concrete to the most abstract – characterises every activity. curiosity drives our search for new solutions, new materials, and new opportunities. challenges thus generate amazing products and customised creations endowed with a soul. we take care of every step of a project, from the embryonic light fitting design stages to the final delivery, from the still untouched blank canvas to the installation of products, and beyond. we strive to be present, always and everywhere, with a sense of responsibility, attention and readiness, to ensure a service that always matches the quality we strive for. we treat our products as artistic creations.

the world is moving fast. technology is progressing at a rapid pace, influencing our lives. artificial intelligence impacts our perception of things and of the world. languages and words evolve, throwing open portals to new worlds and unprecedented interpretations. yet, the word *care* has remained unchanged for two thousand four hundred years, both in form and in substance. likewise, Viabizzuno transforms, matures and broadens its horizons, but its thought is based on certain pillars – craftsmanship, research, industrialisation in the service of quality – to which it has remained faithful since its foundation.

our team's commitment, dedication and passion allow us to create unique products and extraordinary designs studied to enhance any architectural space, making it recognisable. the human factor remains a central distinguishing trait. the care our people seek and demonstrate is what sets us apart.

Viabizzuno uniqueness



innovation



craftsmanship



industrialisation



recognisability



services



Historical Oberameistraße Museum reutlingen, germany

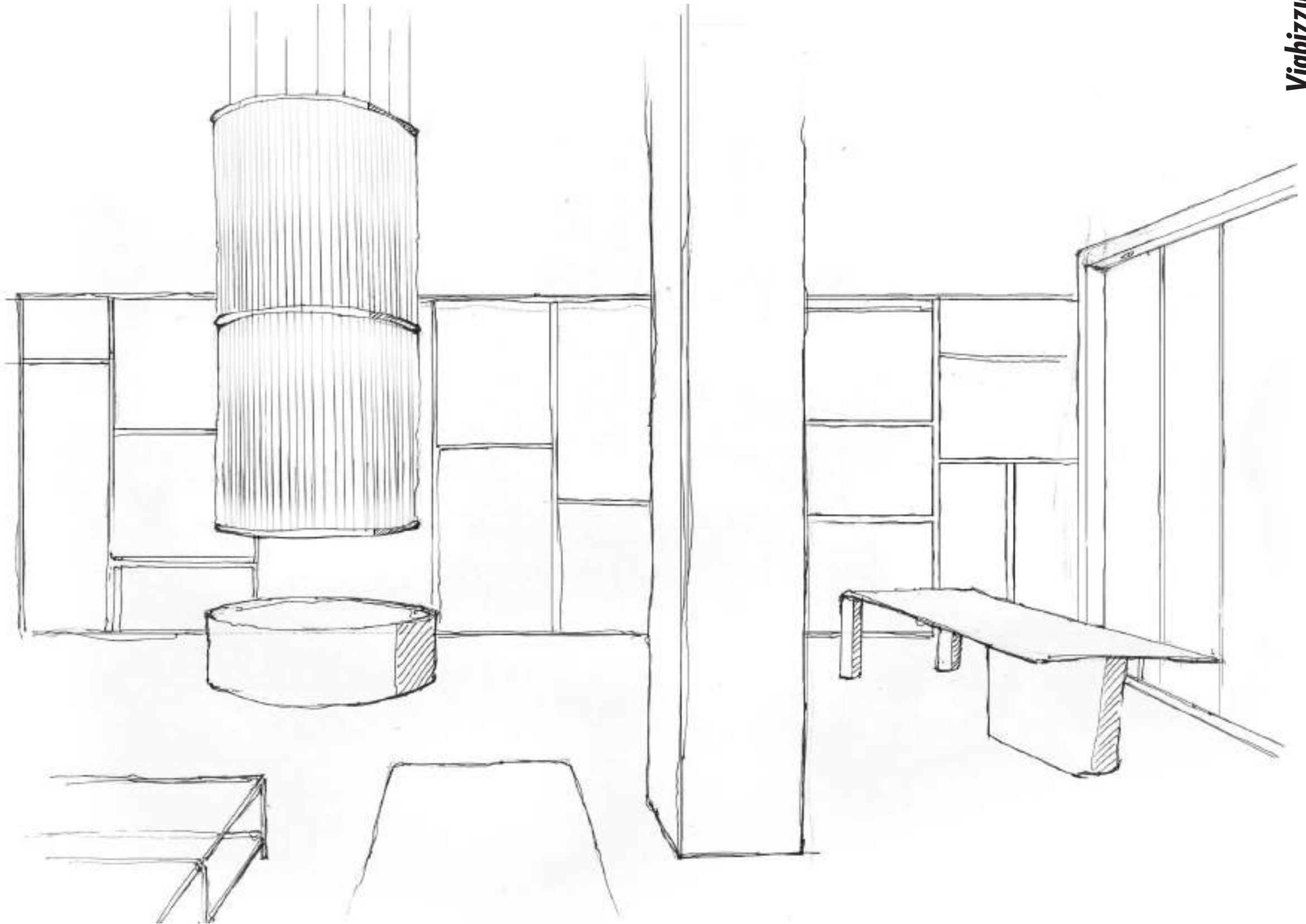

lighting for retail

a variety of needs coexist in retail spaces, to create an atmosphere that encourages customers to dream by stimulating their imagination; to enhance the products on display by highlighting their colours, lines and materials. a well-designed lighting project offers an immersive and memorable experience for users, responding both to functional needs as well as to scenographic creative intent, transforming boutiques into stages with the highest lighting performance. the product on display emerges as a protagonist with dedicated and precise lighting, which remains discreet and naturally guides the eye, while different levels of lighting in the surrounding space create three-dimensional movement, accompanying its evolution without interrupting its balance. the perception of volumes can shift and adapt to changing exhibition layouts. hence, system flexibility is essential. the ability to change the arrangement of light fittings or light intensity independently - without necessarily calling in technicians - ensures both the creation of lighting scenarios that align with the display of the collection, and significant savings in terms of maintenance. in environments that operate for extended hours, such as retail spaces, sustainability relies on choosing products that guarantee high lighting performance with minimal energy consumption, controlled effortlessly via centralised systems. smart lighting management allows to optimise costs and maintenance times, while maintaining quality, efficiency and expressive consistency over time. brand value is expressed through light. a tailor-made project is the basis of an experience that speaks about and enhances the identity of the brand itself, strengthening the link between space, product and desire.

*the intentionally chosen colour for retail lighting is terracotta orange.
its dynamic nature expresses the ability to guide one through an immersive experience, communicating value and enhancing details.*

discover more



www.Viabizzuno.com

high efficiency

quality

integration into furnishings

care for space

value propositions

frequent errors



challenges in retail lighting

- high energy consumption and prohibitive shop running costs
- frequent maintenance and high hidden costs
- absence of light hierarchies
- poor lighting quality
- products not enhanced by lighting
- below-target conversion rate at key sales stages

Viabizzuno quality configuration



- precision lighting
- minimal energy impact
- centralised control
- consistent lighting identity in all environments
- tailor-made design
- customisation options



expression brand communication through lighting



valorisation capable of enhancing beauty



flexibility modular systems that adapt to changing layouts



experience light guiding and building engaging atmospheres



efficiency low consumption and intelligent management to optimise costs and maintenance



connectivity remote lighting control for sustainable and intuitive management of installations

traccia sistema



traccia sistema allows for infinite configurations and customisation. IP20 indoor system made of oxidised extruded aluminium. the traccia sistema allows to create electrified display structures with vertical tracciapiù uprights for floor-to-ceiling installation by attaching adjustable and swivel lower and upper feet Ø80mm or floor to wall by means of a Ø350mm base that does not require floor anchors or a wall mounting bracket.

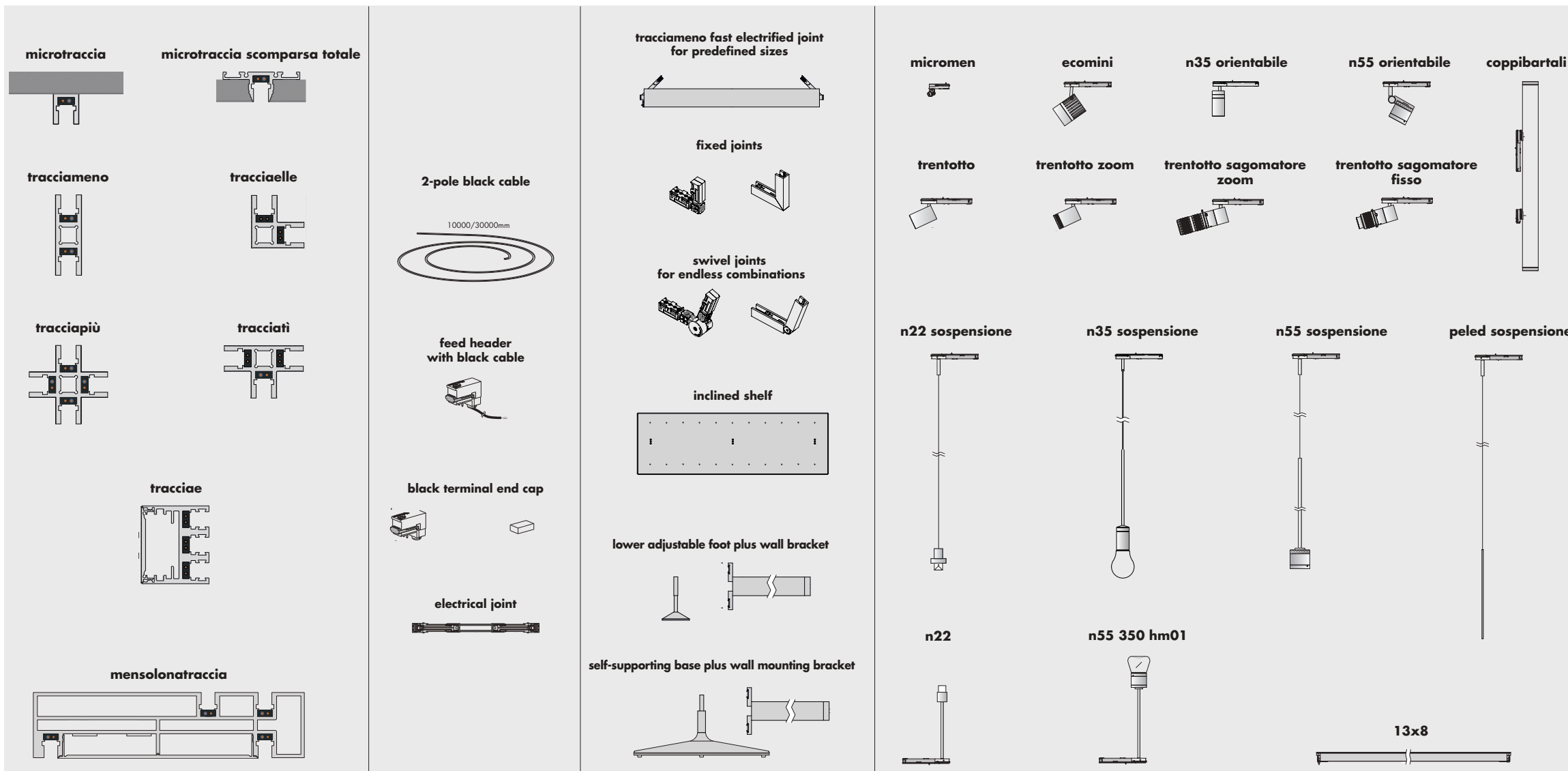
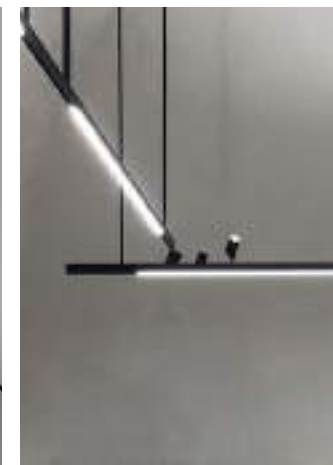

iconic projects



Galeries Lafayette paris, france

a global fashion institution offers a new experience in its historic art déco building



Khaite Madison new york, usa

materiality, refined details and craftsmanship build an unconventional space



Sulwhasoo seoul, south korea

radical transformation of a building inspired by the lantern concept to celebrate the brand's roots



Kith paris, france

an innovative shopping experience in a space that respects the original architectural elements

global references



Apl new york, usa



Onitsuka tiger paris france



Nakhla jewellery store cairo, egypt



Sks showroom chicago, usa



Dolce&Gabbana flagship store new york, usa



Khaite Melrose los angeles, usa



M Essential tianjin, china



Moncler Grenoble st.moritz, switzerland



Marazzi showroom rome, italy



Bestseller shopping mall copenhagen, denmark

products

ceiling



ecomini



n55 parete soffitto orientabile



light box

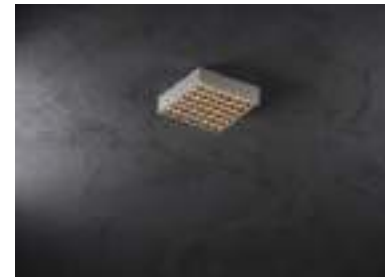

mn sistema



lenticchia

technical suspension



094 sistema



n55 sospensione



traccia sistema sospensione



bacchetta magica



lenticchia

decorative suspension



coppibartali



da ma



candela di vals



aura



oltre

recessed



m1 micro incasso



094 sistema



5x20

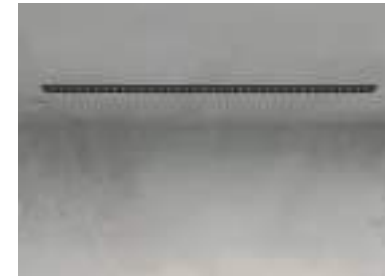

mn sistema



sistema vetrine

wall



coppibartali



light box



n55 h20



royal parete



quasi

**table
floor**



traccia terra



da ma



fiore



roy



n55 tavolo

**230V track
binario trifase VbB**



ecomini binario



n55 binario spot100



n55 binario lensoptica



econo binario

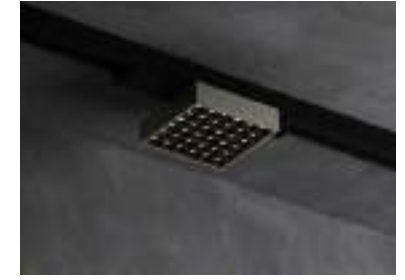

mn sistema

**24Vdc track
traccia sistema**



ecomini



trentotto



n55 lensoptica



n55 spot55x37



micromen

**48Vdc track
A sistema**



n55 spot 55x61



n55 spot 82x79



n55 spot 82x35



n55 lensoptica 180



n55 sagomatore

**connectivity
emergency
wired systems**



Viascenario



trasparenze



n55 emergenza



ticablo



ariacablata

offering



A sistema with n55 spot

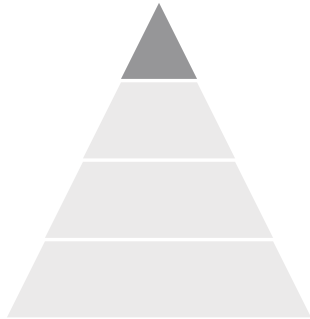

094 sistema with n55

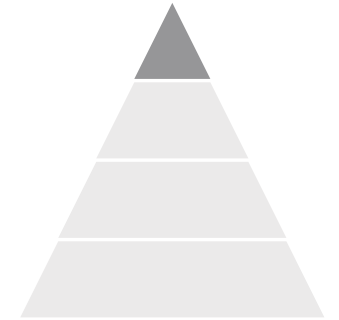

traccia sistema with n55 spot

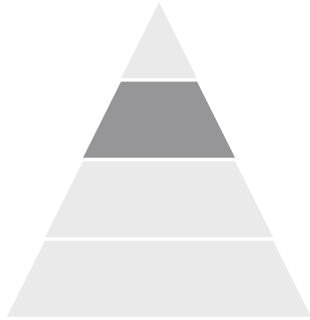

m1 micro incasso

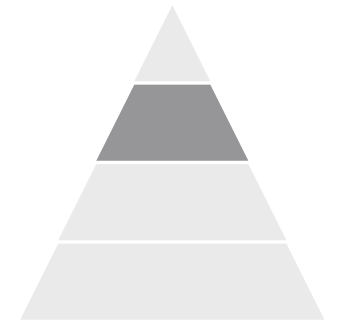

traccia sistema with trentotto

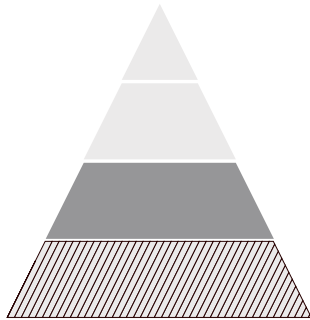

light box

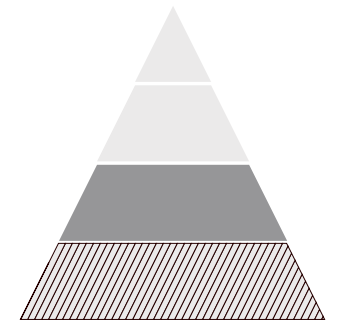

binario trifase VbB with ecomini

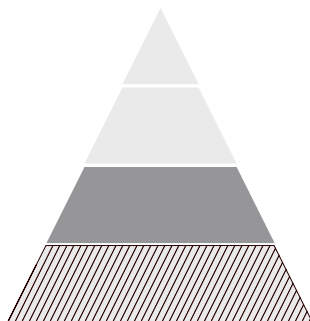

Viabizzuno contract

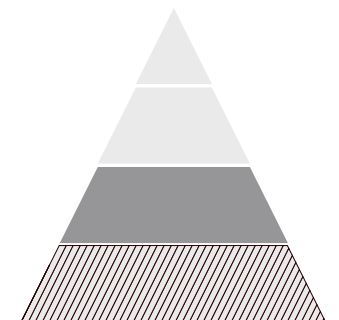

we take care

care is an extraordinary word. short and apparently simple, it encompasses many meanings, which are inextricably linked. *care* from the latin *cūra, curae*. the meaning changes according to the scope. its fields of application are numberless, spanning society and government, religion and architecture. *cūra* is *concern, care, attention* and – by abstraction – *love*. it is also *administration, custodianship, ornamentation, study* and *curiosity*. in medicine, *cūra* means both *giving care* and *taking care*. by no mere coincidence this important word is linked to another latin term: *cor, cordis*, i.e. *heart*. their fusion gives rise to the archaic term *coira*, meaning *care, solicitude* and *medical treatment*, suggesting an origin associated with deep interest and feeling.

Viabizzuno's design approach is based on craftsmanship combined with the highest technology standards to create products that are proudly made in italy. timeless, eternal and outside the trends of fashion products. creativity, tailoring approach and service excellence are our guiding principles, enabling us to take the customers by the hand, accompany them through our experience and take care of every aspect. our industrialisation capacity makes us solid and reliable.

we are curious, we care, we are concerned. at Viabizzuno, the word *care* in all its forms – from the most concrete to the most abstract – characterises every activity. curiosity drives our search for new solutions, new materials, and new opportunities. challenges thus generate amazing products and customised creations endowed with a soul. we take care of every step of a project, from the embryonic light fitting design stages to the final delivery, from the still untouched blank canvas to the installation of products, and beyond. we strive to be present, always and everywhere, with a sense of responsibility, attention and readiness, to ensure a service that always matches the quality we strive for. we treat our products as artistic creations.

the world is moving fast. technology is progressing at a rapid pace, influencing our lives. artificial intelligence impacts our perception of things and of the world. languages and words evolve, throwing open portals to new worlds and unprecedented interpretations. yet, the word *care* has remained unchanged for two thousand four hundred years, both in form and in substance. likewise, Viabizzuno transforms, matures and broadens its horizons, but its thought is based on certain pillars – craftsmanship, research, industrialisation in the service of quality – to which it has remained faithful since its foundation.

our team's commitment, dedication and passion allow us to create unique products and extraordinary designs studied to enhance any architectural space, making it recognisable. the human factor remains a central distinguishing trait. the care our people seek and demonstrate is what sets us apart.

Viabizzuno uniqueness



innovation



craftsmanship



industrialisation



recognisability



services



Sks showroom chicago, usa

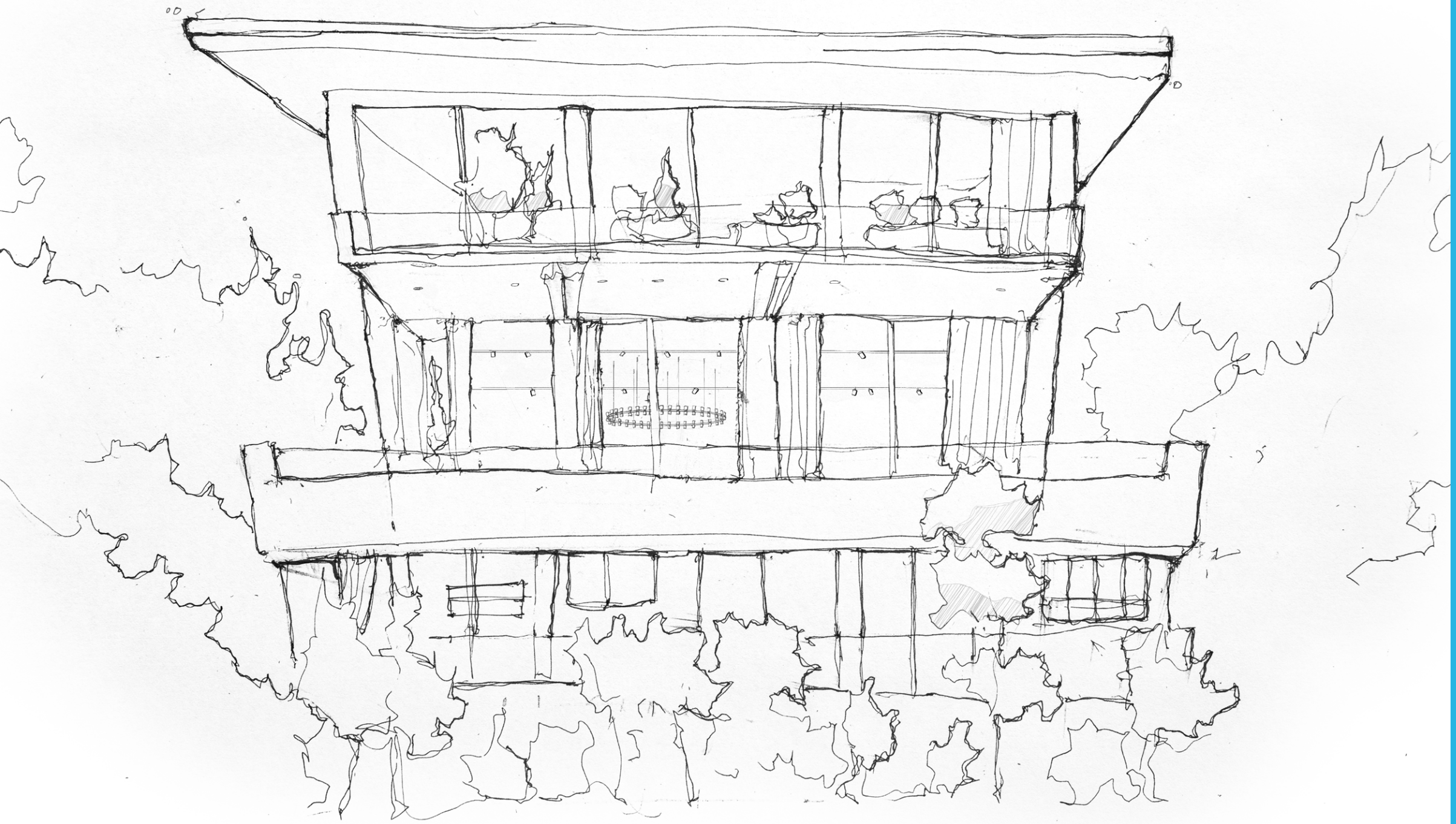

lighting for the home

light is one of the main dimensions of architecture. the coherent and harmonious coexistence of these components gives rise to environments designed for well-being. light is not an object, but the secret ingredient that links all the others, composing an atmosphere capable of guiding emotions and amplifying sensations. Viabizzuno's ability to listen leads to the implementation of lighting projects as tailor-made suits, conceived and realised for the person and his or her needs, studied to enhance architecture and its peculiarities. the possibility of accessing different lighting levels in terms of intensity and various lighting scenarios is central to ensuring natural visual comfort that adapts to the time of day or to the activities taking place in the room. light can also highlight precious objects, works of art and architectural details with a subtle accent. lighting design is a direction of space that must be managed in an accessible and smart way. the Viascenario application makes it possible to create scenarios and programme when the lighting is switched on or turned off by modulating intensity and atmospheres based on different needs, such as the calm of the morning, the conviviality of the evening, and the contemplative silence of the night. sustainability is an integral part of this approach. the search for efficient and energy-saving products is not just a technical choice, but an intentional action that improves the quality of living over time. thanks to sensors, timers and intelligent control systems, light can be adapted to the actual use of space, avoiding waste and without sacrificing comfort. light that is designed to last, that reduces running and maintenance costs, and contributes to a more responsible way of living. in this balance between well-being, technology and care for the environment, light becomes a discreet and respectful presence, capable of enhancing people and accompanying every moment of the home naturally.

*the intentionally chosen colour for home lighting is deep blue.
it conveys serenity and becomes a metaphor for the comfort of one's own home.
confidence, well-being and calm are sought and enhanced through light.*

discover more



www.Viabizzuno.com

well-being

visual comfort

lighting scenes

design

value propositions

frequent errors



challenges in home lighting

- absence of lighting design
- absence of light hierarchies
- impossibility to create lighting scenarios
- dazzling products
- inappropriate colour temperatures
- too little or too much light



well-being light designed to value the pleasure of every moment



tailored lighting for objects, artworks and details: emphasis on paintings, bookcases and niches



rhythm dynamic light that shifts with the moments of the day

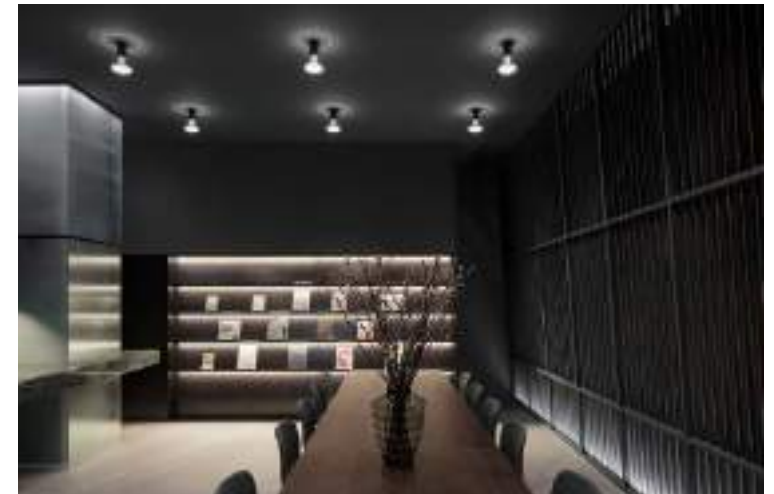

energy saving sensors, timers and dimmers optimise consumption

Viabizzuno quality configuration



- tailor-made lighting design
- high visual comfort and sense of security
- calibrated light in every environment
- efficiency and energy saving
- infinite customisation possibilities
- programmable scenarios
- connectivity via Viascenario



theatricality defines space with elegance



connectivity remote lighting control for sustainable and intuitive management of installations

iconic projects



Secular Retreat devon, england

architecture and landscape come together in a space for living and thinking



Villa Vanke Dajia suzhou, china

a space infused with nature and emotional connections expresses the sensitivity of its inhabitants



Central Park West private residence new york, usa

a loft with natural, textural materials overlooking one of the world's most famous skylines



Crescent House vaucluse, australia

a sculptural building opens up to nature and connects with the landscape

global references



Sentosa Cove private residence singapore



Golden Beach House miami, usa



Bosco Verticale private residence milan, italy



Toranomon tokyo, japan



Historic building in the heart of Milan milan, italy



Historic building in the Magenta district milan, italy



Villa a Cortina d'Ampezzo cortina d'ampezzo, italy



Villa Yuyuan Shaoxing zhejiang, china



Bronte House sydney, australia



private residence via dei giardini milan, italy

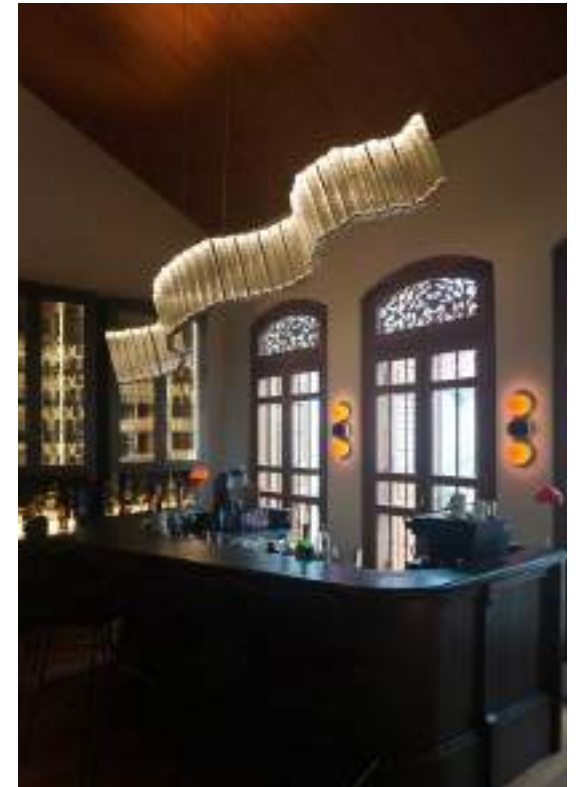

emerald hill conservation shophouse singapore

products

ceiling



n55 soffitto



n22 soffitto



royal soffitto



c sistema



cilindro 58

**technical
decorative
suspension**



n55 sospensione



n22 sospensione



aura



sempre mia



candela di vals

**digrandebellezza
suspension**



oltre



coppibartali



da ma



royal chandelier



tissoffio

recessed



m1 micro incasso



profili lineari



raggio



foro



intè sistema

wall



coppibartali



n22 parete con braccio



royal parete



quasi



lancilotto parete

table



da ma



coppibartali



n55 tavolo



roy



minima

floor



da ma



coppibartali



traccia terra



roy



minima

battery-powered portable lamps



lanterna tirolese



manondovevamoavederci più



n55 lanterna



n55 torcia



bulletta

furnishing systems

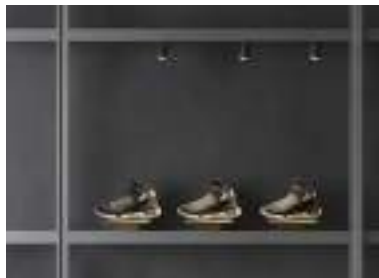

traccia sistema



men sole



cisei sistema



corrimano in luce

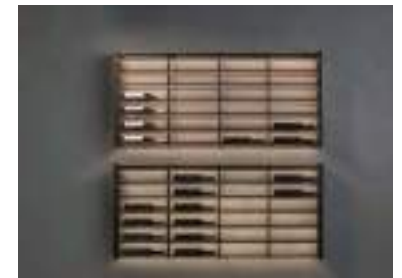

bottigliera

**24Vdc track
traccia sistema**



micromen



trentotto



trentotto sagomatore



ecomini



n55 orientabile

offering



oltre

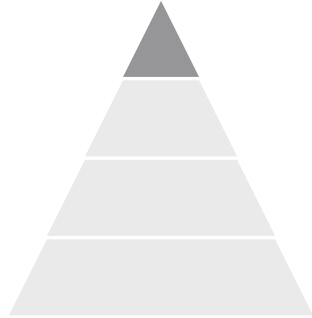

tisoffio

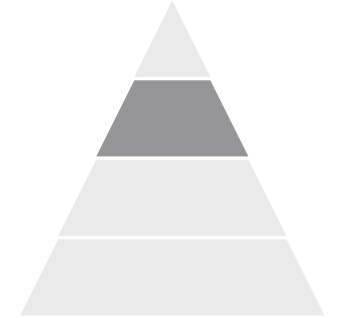

coppibartali

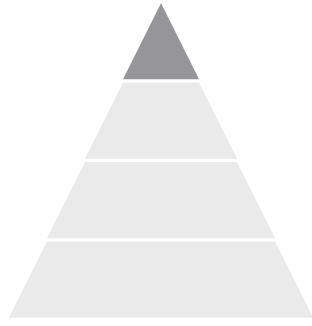

n55 sospensione

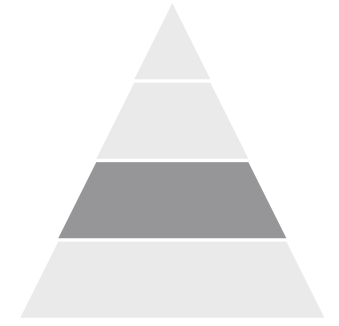

da ma

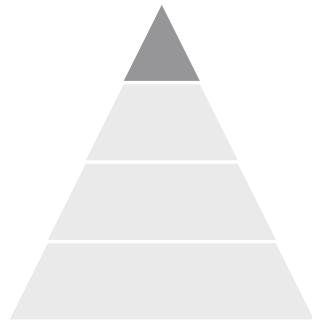

aura

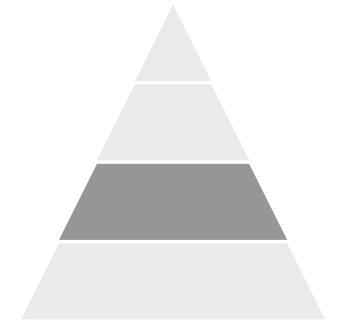

royal chandelier

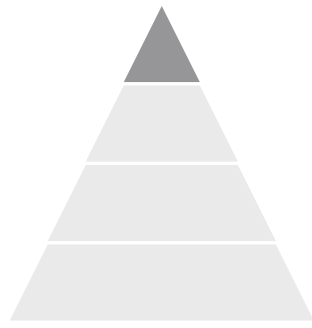

n22 sospensione

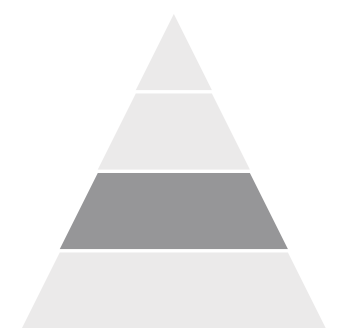

we take care

care is an extraordinary word. short and apparently simple, it encompasses many meanings, which are inextricably linked. *care* from the latin *cūra, curae*. the meaning changes according to the scope. its fields of application are numberless, spanning society and government, religion and architecture. *cūra* is *concern, care, attention* and – by abstraction – *love*. it is also *administration, custodianship, ornamentation, study* and *curiosity*. in medicine, *cūra* means both *giving care* and *taking care*. by no mere coincidence this important word is linked to another latin term: *cor, cordis*, i.e. *heart*. their fusion gives rise to the archaic term *coira*, meaning *care, solicitude* and *medical treatment*, suggesting an origin associated with deep interest and feeling.

Viabizzuno's design approach is based on craftsmanship combined with the highest technology standards to create products that are proudly made in italy. timeless, eternal and outside the trends of fashion products. creativity, tailoring approach and service excellence are our guiding principles, enabling us to take the customers by the hand, accompany them through our experience and take care of every aspect. our industrialisation capacity makes us solid and reliable.

we are curious, we care, we are concerned. at Viabizzuno, the word *care* in all its forms – from the most concrete to the most abstract – characterises every activity. curiosity drives our search for new solutions, new materials, and new opportunities. challenges thus generate amazing products and customised creations endowed with a soul. we take care of every step of a project, from the embryonic light fitting design stages to the final delivery, from the still untouched blank canvas to the installation of products, and beyond. we strive to be present, always and everywhere, with a sense of responsibility, attention and readiness, to ensure a service that always matches the quality we strive for. we treat our products as artistic creations.

the world is moving fast. technology is progressing at a rapid pace, influencing our lives. artificial intelligence impacts our perception of things and of the world. languages and words evolve, throwing open portals to new worlds and unprecedented interpretations. yet, the word *care* has remained unchanged for two thousand four hundred years, both in form and in substance. likewise, Viabizzuno transforms, matures and broadens its horizons, but its thought is based on certain pillars – craftsmanship, research, industrialisation in the service of quality – to which it has remained faithful since its foundation.

our team's commitment, dedication and passion allow us to create unique products and extraordinary designs studied to enhance any architectural space, making it recognisable. the human factor remains a central distinguishing trait. the care our people seek and demonstrate is what sets us apart.

Viabizzuno uniqueness



innovation



craftsmanship



industrialisation



recognisability



services



Sentosa Cove private residence singapore

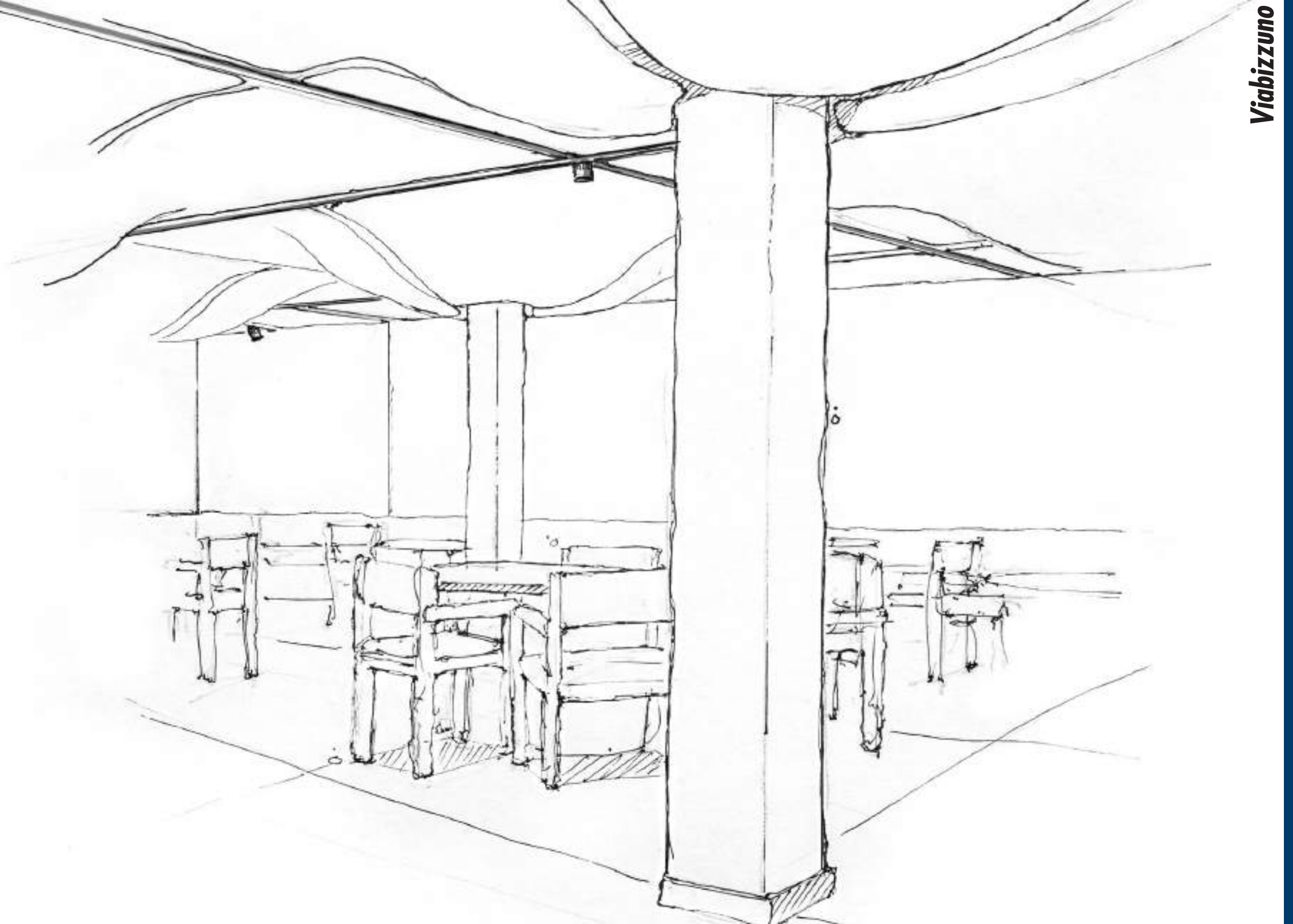

lighting for hospitality

when you conceive the lighting design for a space dedicated to hospitality, you create an element that is much more than just a visual aid: it is a tool that generates atmospheres, guides guests, enhances any environment, and conveys a message. light, more than any other material element, has the power to either welcome or repel. environments within the same built space can present remarkable differences. hence, the task of light is first and foremost to ensure coherence and visual continuity by making spaces dialogue harmoniously, while respecting their identity and function. light must be able to adapt to the different needs and moments of the day, customising every settings: from the conviviality of a restaurant, to the relaxation of a spa, and the warmth of a hall. this is achieved by adopting flexible solutions in which light fittings can be easily repositioned or customised without involving specialised technicians. even for large-scale projects, flexibility, control and uniformity must be ensured without renouncing elegance or customisation. light must be able to enhance the beauty of materials, finishes, shapes, volumes and details, while enhancing objects, works of art and furnishings. emergency signs too discretely fits into the picture, ensuring safety without altering the overall atmosphere. in every hospitality space, light thus becomes an invisible thread that guides, excites and defines the experience of guests, transforming environments into warm, memorable and refined places.

the reference colour for hospitality is midnight blue, a symbol of calm and depth that creates well-being. in these spaces, light is capable of making you feel at home even when you are away from home.

discover more



www.Viabizzuno.com

comfort

orientation and safety

energy saving

compliance with regulations

value propositions

frequent errors



lighting challenges in hospitality

- high energy consumption and high running costs
- complex and unintuitive control systems for guests and staff
- different lighting scenes in each room • poor design culture: glare, poor uniformity, inadequate colour rendering



identity light that endows space with personality



atmosphere environments that can be customised to suit the needs and the use of space



valorisation capable of enhancing architectural beauty



safety emergency signs for discrete guidance

Viabizzuno quality configuration



- comprehensive offering for all budget requirements
- efficiency: sensors and programming to reduce waste
- intuitive control of lighting scenarios
- safety and compliance
- furnishing systems integrated into architecture



cost-consciousness lighting systems for large-scale projects



connectivity remote lighting control for sustainable and intuitive management of installations

aura



'rather than designing an object that accommodates light, we set ourselves the goal of designing light itself - sculpting it with precision and control. this collection embodies the intersection of physics, engineering and design, achieved by a close partnership with Viabizzuno. together, we redefined what can be done with light.'

marius myking
director of product design snøhetta

fusion of technology and design: the specific orientation of the LEDs sculpts a vortex of light that directs the light beam with extreme precision into the characteristic conical diffuser.



diffuser in polymethylmethacrylate: highly transparent material capable of transmitting light while minimising absorption losses.

material	absorption coefficient α
soda lime glass	0.017 mm ⁻¹
polycarbonate	0.004 mm ⁻¹
polymethylmethacrylate	0.0014 mm⁻¹

recyclable packaging, composed of paper and high-strength korrvu film to wrap the products, protecting them from impact and vibrations

efficient use of light through **control systems and sensors**

part of the **ESG programme**.
(see our report on Viabizzuno.com)

IP20 rated suspension light fitting for indoor use. made of polymethylmethacrylate and aluminium. suspension and power cables made of copper-plated steel and brass braiding.

finishes
transparent, chrome-plated

versions
suspension and saliscendi, power supply excluded 3000K

maximum flexibility
possible creation of endless compositions

latest generation LEDs
Ra97: 5.5W, 103 lm/W, 2 steps sdcm



models

suspension

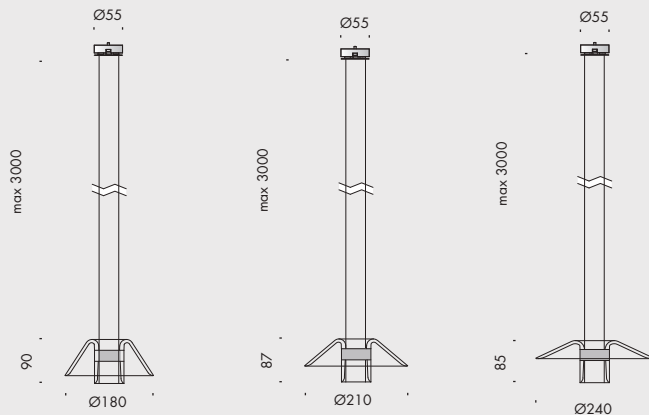

saliscendi

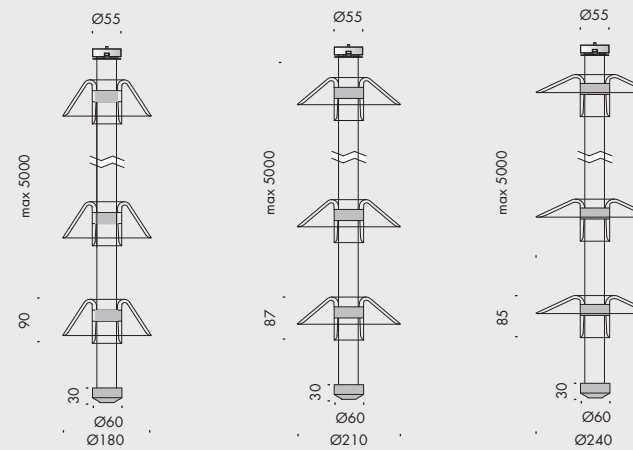

customisable saliscendi

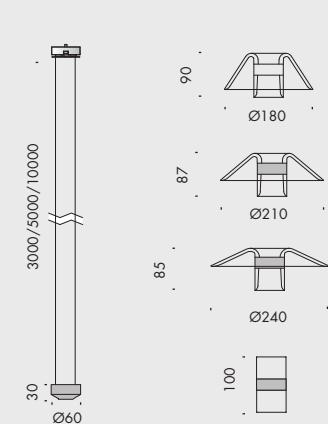

iconic projects



Thermo Vals vals, switzerland

a worldwide architectural reference based on stone, water and light



Garage Italia milan, italy

an iconic former gas station converted into a space of made-in-Italy excellence



hotel Café Royal london, england

a historical landmark for fashion, art and culture in one of the world's choicest neighbourhoods



Vesta Restaurant milan, italy

impressive architecture that merges interior and exterior through materiality and lighting

lighting for hospitality

global references



Tankoa T55 genoa, italy

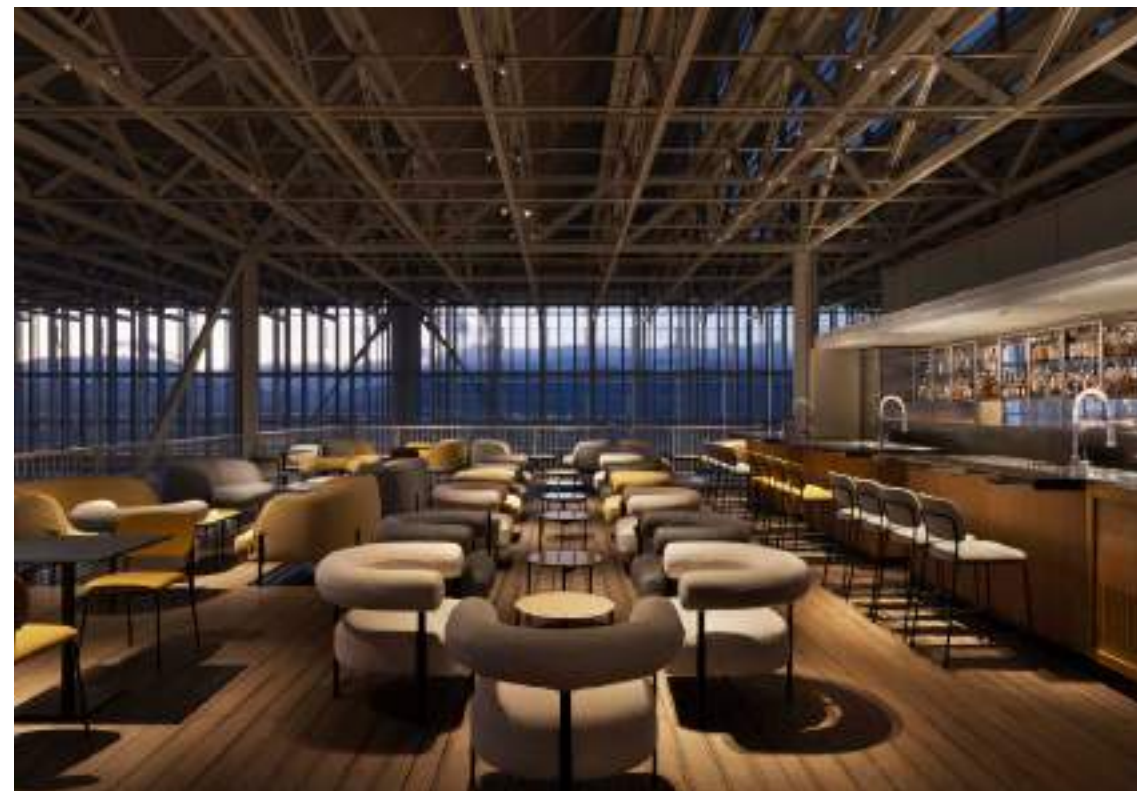

Piano35 lounge bar milan, italy



Dragon restaurant paris, france



Alouette restaurant copenhagen, denmark



Telegraph hotel tbilisi, georgia



Ambassaden oslo, norway



Hotel Jakarta amsterdam, netherlands



Shy Table restaurant hangzhou, china



Riela Bath House madrid, spain



Sol's london, united kingdom

products

ceiling



n55 soffitto



n22



royal soffitto



lenticchia



c sistema

**technical
decorative
suspension**



n55 sospensione



n22 sospensione



aura



sempre mia



candela di vals

**digrandebellezza
suspension**



oltre



coppibartali



da ma



royal chandelier



tissoffio

recessed



m1 micro incasso



094 sistema



profili lineari



foro



intè sistema

wall



coppibartali



n22 parete con braccio



royal parete



quasi



lancillotto parete

table



da ma



coppibartali



n55 tavolo



roy



minima

floor



da ma



coppibartali



traccia terra



roy



minima

battery-powered portable lamps



lanterna tirolese



manondovevamovedercipiù



n55 lanterna



n55 torcia



bulletta

**24Vdc track
traccia sistema**



micromen



trentotto



trentotto sagomatore



ecomini



n55 orientabile

**connectivity
emergency
wired systems**



Viascenario



trasparenze



n55 emergenza



ticablo



ariacablata

offering



oltre

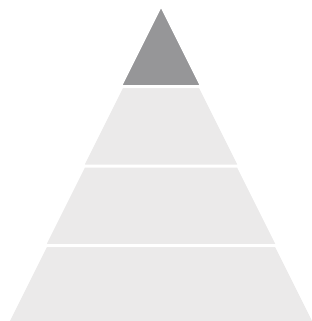

trasparenze

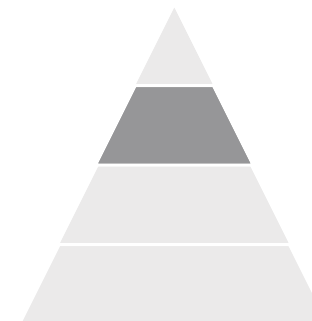

coppibartali

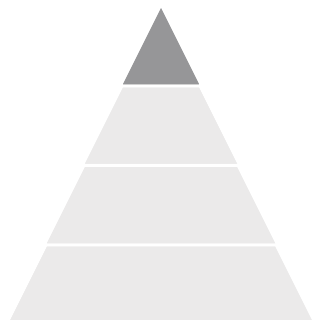

traccia sistema

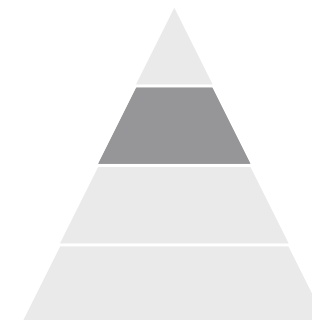

royal chandelier

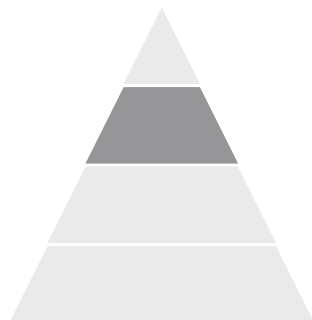

m1 micro incasso

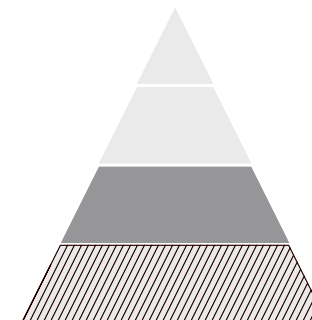

aura

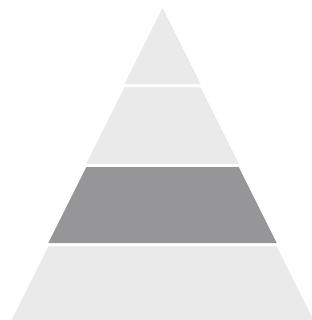

Viabizzuno contract

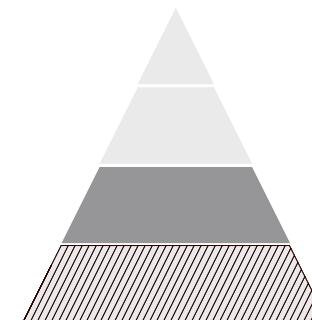

we take care

care is an extraordinary word. short and apparently simple, it encompasses many meanings, which are inextricably linked. *care* from the latin *cūra, curae*. the meaning changes according to the scope. its fields of application are numberless, spanning society and government, religion and architecture. *cūra* is *concern, care, attention* and – by abstraction – *love*. it is also *administration, custodianship, ornamentation, study* and *curiosity*. in medicine, *cūra* means both *giving care* and *taking care*. by no mere coincidence this important word is linked to another latin term: *cor, cordis*, i.e. *heart*. their fusion gives rise to the archaic term *coira*, meaning *care, solicitude* and *medical treatment*, suggesting an origin associated with deep interest and feeling.

Viabizzuno's design approach is based on craftsmanship combined with the highest technology standards to create products that are proudly made in italy. timeless, eternal and outside the trends of fashion products. creativity, tailoring approach and service excellence are our guiding principles, enabling us to take the customers by the hand, accompany them through our experience and take care of every aspect. our industrialisation capacity makes us solid and reliable.

we are curious, we care, we are concerned. at Viabizzuno, the word *care* in all its forms – from the most concrete to the most abstract – characterises every activity. curiosity drives our search for new solutions, new materials, and new opportunities. challenges thus generate amazing products and customised creations endowed with a soul. we take care of every step of a project, from the embryonic light fitting design stages to the final delivery, from the still untouched blank canvas to the installation of products, and beyond. we strive to be present, always and everywhere, with a sense of responsibility, attention and readiness, to ensure a service that always matches the quality we strive for. we treat our products as artistic creations.

the world is moving fast. technology is progressing at a rapid pace, influencing our lives. artificial intelligence impacts our perception of things and of the world. languages and words evolve, throwing open portals to new worlds and unprecedented interpretations. yet, the word *care* has remained unchanged for two thousand four hundred years, both in form and in substance. likewise, Viabizzuno transforms, matures and broadens its horizons, but its thought is based on certain pillars – craftsmanship, research, industrialisation in the service of quality – to which it has remained faithful since its foundation.

our team's commitment, dedication and passion allow us to create unique products and extraordinary designs studied to enhance any architectural space, making it recognisable. the human factor remains a central distinguishing trait. the care our people seek and demonstrate is what sets us apart.

Viabizzuno uniqueness



innovation



craftsmanship



industrialisation



recognisability



services



Alouette Restaurant copenhagen, denmark

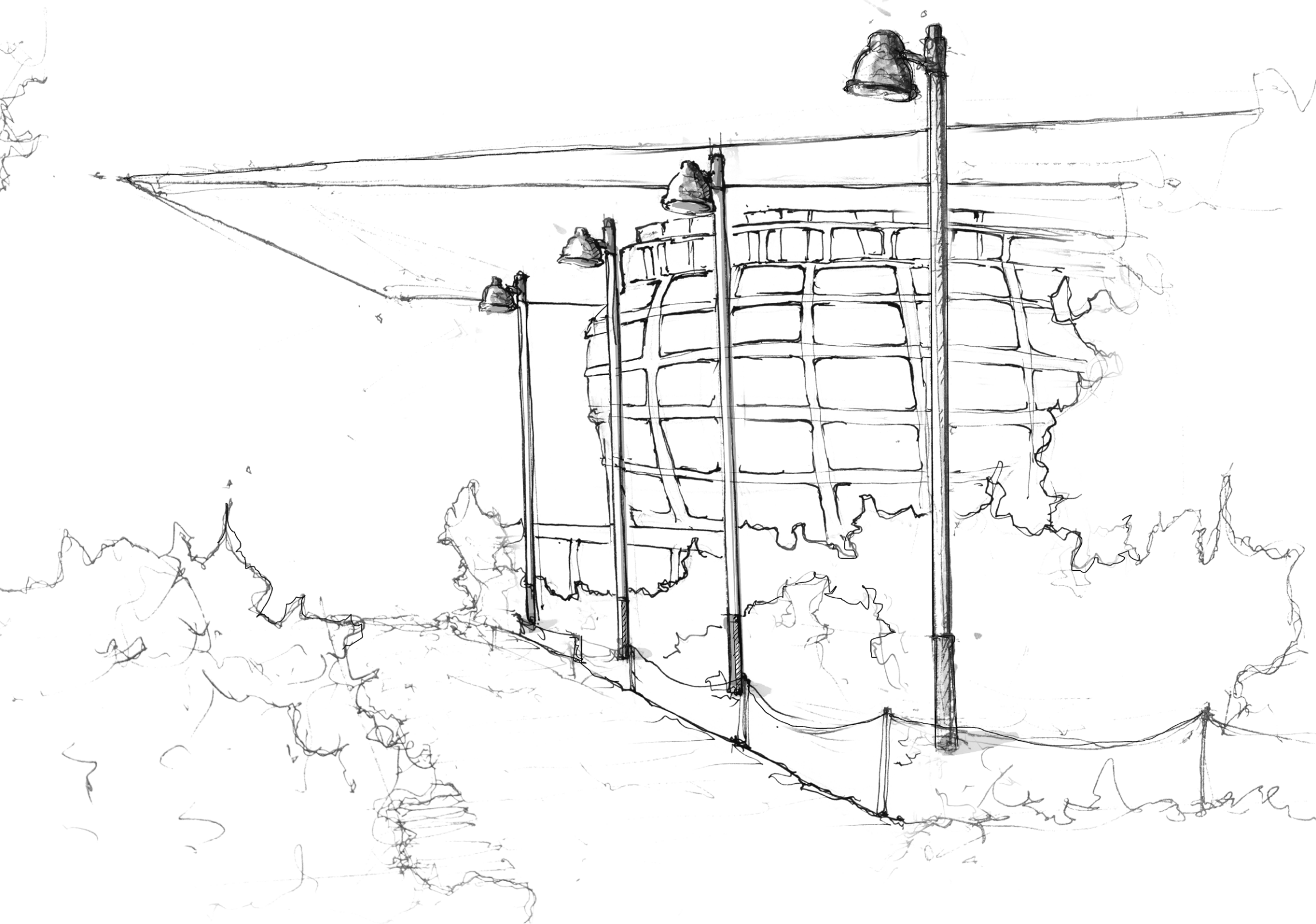

lighting for outdoor spaces

illuminating is not just a matter of seeing, especially when the design concerns outdoor spaces such as courtyards, gardens, parks and façades. a number of elements must be equally respected. the delicate balance in which they exist is what creates the magic. designing different, complementary levels of lighting - diffuse, functional and accent lighting - creates a dialogue between architecture and landscape through a coherent language that transforms the outdoors into an emotional journey. light is a guide: it builds paths, clearly defining passages and landmarks. light fittings must be designed to fulfil this function while ensuring the utmost visual comfort, avoiding glare effects, and unnecessary upward light dispersion. respecting the environment means complying with regulations, while enhancing natural and built elements, besides the details of the environment itself. uniform controlled emission ensures a harmonious lighting experience, as does the choice of technical interventions that do not impair the originality of existing elements. indeed, selecting flexible systems means adapting human action to evolving spaces, to the changes both in natural elements and in needs. the virtuous coexistence of architectural container, content and surrounding environment occurs through coherent lighting, capable of enhancing every facet of a place's identity. design merges with the landscape, becoming a discreet but essential companion. to illuminate is to narrate, to guide, to surprise. it means transforming every outdoor space into an immersive experience.

the intentionally chosen colour for outdoor lighting is straw yellow. its warmth conveys safety, a feeling that human beings need to experience when walking down the street, in a park or in a courtyard at night. yellow is also reminiscent of the sun, a natural source of energy that does not generate waste.

discover more



www.Viabizzuno.com

enhanced outdoor spaces

energy saving

innovative control system

robustness and durability

value propositions

frequent errors



challenges in outdoor lighting

- light pollution and glare
- uneven levels: dark areas followed by overlighting
- degradation over time (saltiness, humidity, impact) and unsuitable finishes
- high consumption due to permanently activated or poorly regulated systems
- poor integration with architecture and landscape



dark-sky optics designed to reduce glare and upward light dispersion



visual comfort uniform, controlled emission without glare



promotion illumination and visual communication via replaceable banners



retrofit targeted interventions on existing installations, guaranteed continuity

Viabizzuno quality configuration



- maximum visual and anti-glare comfort
- weathering and corrosion-resistant materials and finishes
- enhancement of green areas
- design that blends into the landscape
- flexible electronic equipment
- vehicle for promotional messages
- safety: legible paths, thresholds and obstacles emphasised without excessive light



night-time identity light converses with architecture



architectural continuity a unified lighting language connecting interior and exterior

nett uno



IP65, wall and floor light fitting, for indoor and outdoor use. made of oxidised and powder-coated aluminium.
finishes: bruno antico, nero notte, scurodivals, grigio argento



nett uno 40

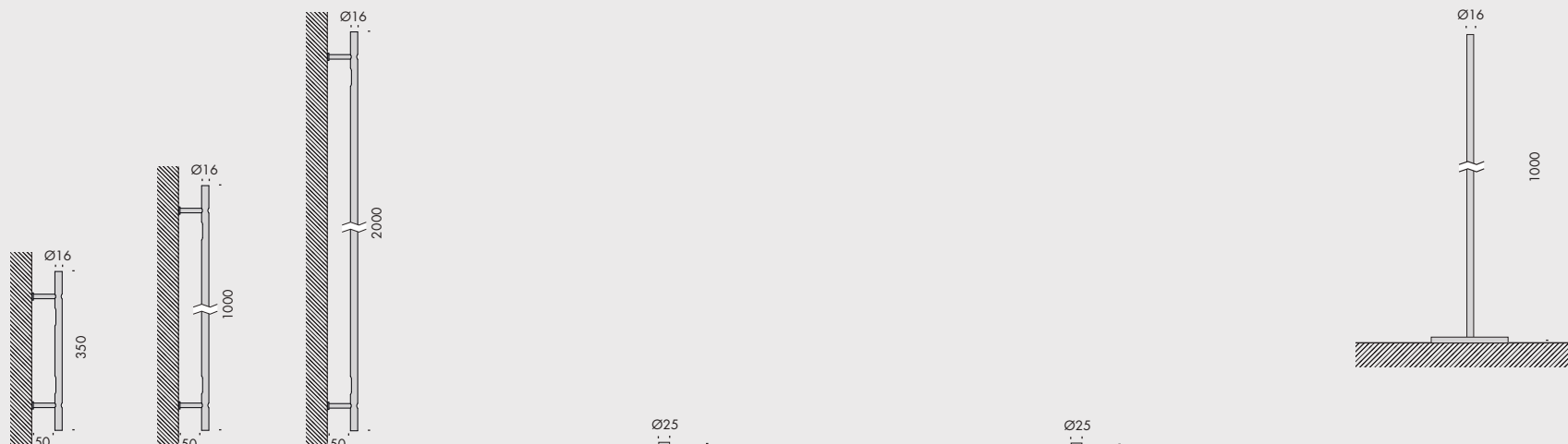

nett uno 80

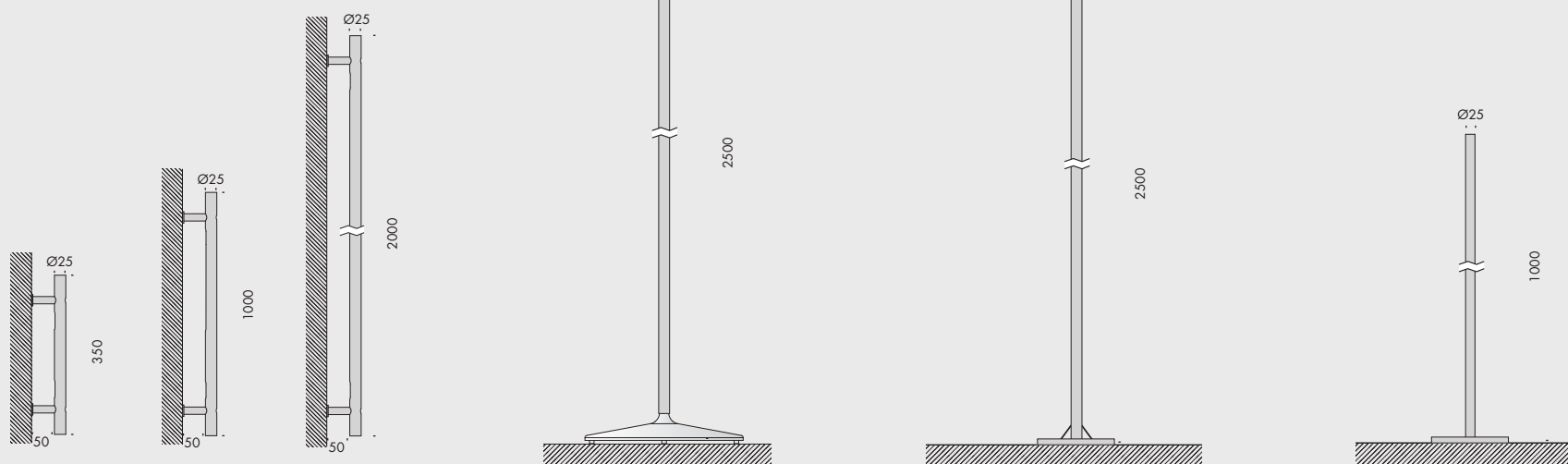

nett uno 100

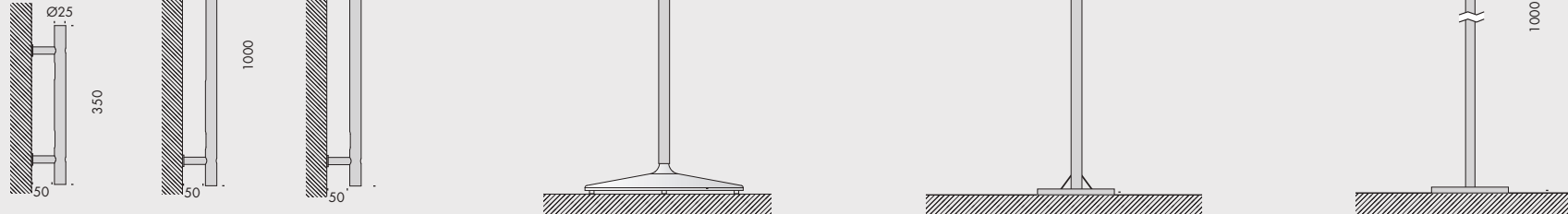
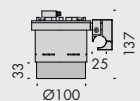

iconic projects



Piazza del Nettuno bologna, italy *light and shadow establish a dialogue with an artistic and cultural symbol in the heart of the city*



Annenstrasse graz, austria *a historic street, a symbol of modernity, leads to a unesco heritage site*



Sentieri di Vals vals, switzerland *a landscape and introspective journey featuring blurred boundaries between nature and design*



Inagawa Cemetery inagawa, japan *natural and artificial light merge in the pure volumes of a space dedicated to contemplation*

global references



Pt. Leo victoria, australia



Reggia di Rivalta reggio emilia, italy



Operaparken copenhagen, denmark



Gres Art 671 bergamo, italy



Wood Lake House connecticut, usa



Bologna Business School bologna, italy



Viale Ceccarini riccione, italy



State Archives naples, italy



a Fairytale Woodland by the lake m, russia



Piazza degli Arcipelaghi cagliari, italy

products

ceiling



lanterna massima



lenticchia



cilindro 58



c sistema c2 30x32



leis

suspension



catenaria di luce serpentine



lanterna massima



biblio



bacchetta magica



silère

floor stake



lucciola



p1



p2



cubo paletto 15



erste

recessed



m1 micro incasso



m18



m4



tsukimiso



zero

wall



nett uno



silere



lanterna tirolese



lanterna massima



campanula

façades



lunar



unaghi

battery-powered portable lamps



lanterna tirolese



n55 lanterna



n55 torcia



manondovevamovederci più



bulletta

spotlights



nett uno



p1



p2



biblio palo
h max: 4000mm

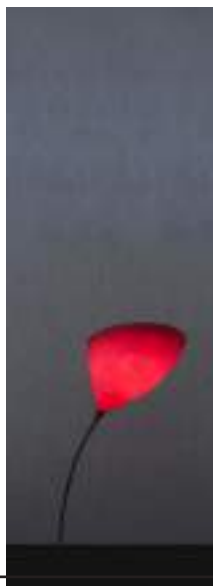

maxxi poppy
h max: 4350mm



lilia
h max: 4350mm



lanterna massima
h max: 4500mm

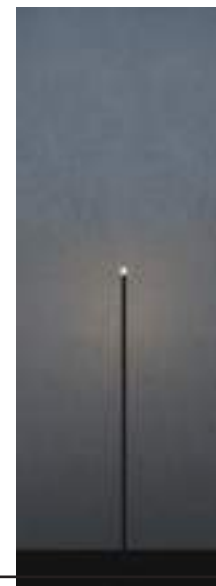

palo b.
h max: 5000mm



sentiero di vals
h max: 5200mm



palo gonfalone
h max: 7700mm



cubo palo
h max: 8000mm



lucus
h max: 9000mm

offering



neff uno

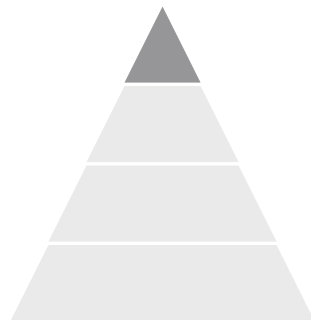

tsukimiso

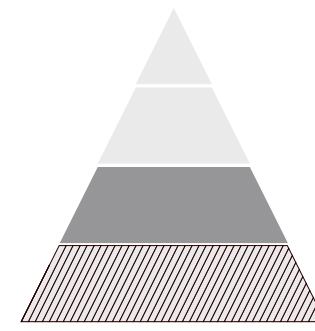

cubo palette 15

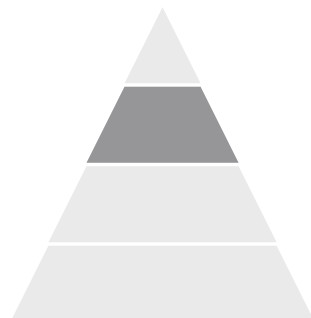

p1 - p2

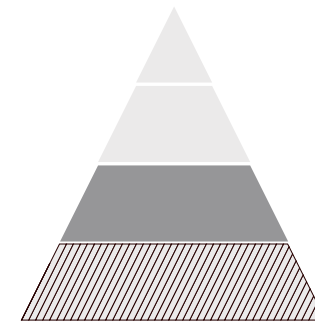

we take care

care is an extraordinary word. short and apparently simple, it encompasses many meanings, which are inextricably linked. *care* from the latin *cūra, curae*. the meaning changes according to the scope. its fields of application are numberless, spanning society and government, religion and architecture. *cūra* is *concern, care, attention* and – by abstraction – *love*. it is also *administration, custodianship, ornamentation, study* and *curiosity*. in medicine, *cūra* means both *giving care* and *taking care*. by no mere coincidence this important word is linked to another latin term: *cor, cordis*, i.e. *heart*. their fusion gives rise to the archaic term *coira*, meaning *care, solicitude* and *medical treatment*, suggesting an origin associated with deep interest and feeling.

Viabizzuno's design approach is based on craftsmanship combined with the highest technology standards to create products that are proudly made in italy. timeless, eternal and outside the trends of fashion products. creativity, tailoring approach and service excellence are our guiding principles, enabling us to take the customers by the hand, accompany them through our experience and take care of every aspect. our industrialisation capacity makes us solid and reliable.

we are curious, we care, we are concerned. at Viabizzuno, the word *care* in all its forms – from the most concrete to the most abstract – characterises every activity. curiosity drives our search for new solutions, new materials, and new opportunities. challenges thus generate amazing products and customised creations endowed with a soul. we take care of every step of a project, from the embryonic light fitting design stages to the final delivery, from the still untouched blank canvas to the installation of products, and beyond. we strive to be present, always and everywhere, with a sense of responsibility, attention and readiness, to ensure a service that always matches the quality we strive for. we treat our products as artistic creations.

the world is moving fast. technology is progressing at a rapid pace, influencing our lives. artificial intelligence impacts our perception of things and of the world. languages and words evolve, throwing open portals to new worlds and unprecedented interpretations. yet, the word *care* has remained unchanged for two thousand four hundred years, both in form and in substance. likewise, Viabizzuno transforms, matures and broadens its horizons, but its thought is based on certain pillars – craftsmanship, research, industrialisation in the service of quality – to which it has remained faithful since its foundation.

our team's commitment, dedication and passion allow us to create unique products and extraordinary designs studied to enhance any architectural space, making it recognisable. the human factor remains a central distinguishing trait. the care our people seek and demonstrate is what sets us apart.

Viabizzuno uniqueness



innovation



craftsmanship



industrialisation



recognisability



services



Operaparken copenhagen, denmark